

Embedded low power radio modem

MU-2-R 434MHz

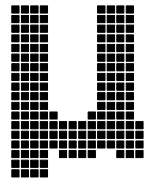

Operation Guide

Version 0.8 (Mar. 2008)

CIRCUIT DESIGN, INC.,

7557-1 Hotaka, Azumino
Nagano 399-8303, JAPAN
Tel: +81+(0)263-82-1024
Fax: +81+(0)263-82-1016

E-mail: info@circuitdesign.jp
Web site: <http://www.cdt21.com>

Contents

Chapter 1	The MU-2-R	4
1.1	Outline	4
1.1.1	Features	4
1.1.2	Applications	4
1.2	Block Diagram	5
1.3	Example of the Control Method	6
1.3.1	Example 1: Controlling the MU-2-R with the on-board CPU	6
1.3.2	Example 2: Controlling the MU-2-R via RS232C	6
Chapter 2	Specifications and Diagram	7
2.1	Main Specifications	7
2.1.1	General specifications	7
2.1.2	UART interface specifications	7
2.2	Terminal Specifications	8
2.3	Channel Table	10
2.4	Dimensional Drawing	12
2.4.1	External dimensions	12
2.4.2	Diagram of dimensions for hole positions	12
Chapter 3	How to Use the MU-2-R	13
3.1	Communication Concept	13
3.1.1	Station types and link parameters	13
3.1.2	Basic data transmission	14
3.1.3	The data transmit commands	15
3.1.4	The link parameters	16
3.1.5	Conditions for establishing a link	16
3.2	System Configuration (When the Relay Function is Not Used)	17
3.2.1	Communication within a group	17
3.3	System Configuration (When the Relay Function is Used)	18
3.3.1	Transmission with the route register route information	18
3.3.2	Transmission with the route information entered in the transmit command	18
3.3.3	1:N relay system	19
3.4	Modes	20
3.4.1	Command mode	20
3.4.2	Text mode	20
3.4.3	Binary mode	20
3.4.4	Mode setting	21
3.5	Resetting	22
3.6	Initializing	22
3.7	Changing channels	22
3.8	Standby mode	23
3.9	Antenna power setting	23
3.10	Communication protocols	23
Chapter 4	Commands, Responses and Receives	24
4.1	About the Commands, Responses and Receives	24
4.2	Command, Response and Receive Table	28
4.2.1	Data transmit commands and data transmit responses	28
4.2.2	Data receives	28
4.2.3	Control commands and control responses	29
4.2.4	Monitor commands and monitor responses	29
4.2.5	Test commands and test responses	30
4.2.6	Extended commands and extended responses	30
4.2.7	Receive response	30

4.2.8 ACK response	30
4.2.9 Information response	30
4.2.10 Error response	30
4.3 Save Setting Command Options	31
4.4 Command, Response and Receive Details	32
4.4.1 Data transmit commands, responses and data receives	32
4.4.1.1 @DT Data transmit command 1	33
4.4.1.2 @DT.../ Data transmit command 2	34
Receive confirmation acknowledgement: no ACK	34
Receive confirmation acknowledgement: with ACK	35
4.4.1.3 @DT...% Data control transmission command 3	37
Receive confirmation acknowledgement: no ACK	37
Receive confirmation acknowledgement: with ACK	38
4.4.2 Control commands and control responses	40
4.4.2.1 @BR UART baud rate setting	40
4.4.2.2 @CH Frequency channel setting	40
4.4.2.3 @DI Destination ID setting	41
4.4.2.4 @EC Error correction protocol setting	41
4.4.2.5 @EI Equipment ID setting	42
4.4.2.6 @GI Group ID setting	42
4.4.2.7 @IZ Initialize	42
4.4.2.8 @MD Operation mode register setting	42
4.4.2.9 @PB UART parity bit setting	42
4.4.2.10 @PW Antenna power setting	43
4.4.2.11 @RM Response display mode	43
4.4.2.12 @RT Relay route designation	43
4.4.2.13 @SB UART stop bit setting	43
4.4.2.14 @SI Mode setting with RF received signal level information	44
4.4.2.15 @SR Reset	44
4.4.2.16 @TB Time without input in the binary mode setting	44
4.4.2.17 @UI User ID setting	45
4.4.3 Monitor commands and responses	46
4.4.3.1 @CR Target station RSSI measurement	46
4.4.3.2 @RA RSSI absolute value measurement	47
4.4.4 Test commands and test responses	47
4.4.4.1 @CT Test data transmission	47
4.4.4.2 @CP Packet test	48
4.4.5 Extended commands and extended responses	49
4.4.5.1 Change the target station channel	49
4.4.5.2 Changing the channels of multiple stations at once	50
4.4.5.3 Issue target station test data	51
4.4.6 Receive response	52
4.4.7 ACK response	52
4.4.8 Error response	52

Chapter 1 The MU-2-R

1.1 Outline

The MU-2-R is an embedded low power radio modem for transmission of serial data. Since it is possible to control the radio component using dedicated simple commands, the user can concentrate on developing the transmitting and receiving programs for their system. For communication protocols, the MU-2-R has a standard protocol and an error correction protocol which performs error correction on the receiver side. Since the error correction protocol uses Reed-Solomon code^{*1} that has strong error correction ability even in environments prone to burst errors, the user can configure highly reliable systems compared to conventional radio modems. Transmitting and receiving data and issuing commands are performed using a UART^{*2} interface with a single-chip CPU and also can be controlled via the COM port (RS232C format) of the computer, making it possible that the user can develop systems quickly^{*3}. In addition, using a maximum of 10 relay stations, it is possible to gather data from and control equipment in remote locations. The MU-2-R is designed to minimize design difficulties involving the high frequency components, so that the user can embed it in their system with peace of mind.

☞ Important

It is not possible simply to replace communication using existing RS232C system equipment connected with a cable, with MU-2-R wireless communication. In order to build wireless systems, the issue specific to radio communications should be solved. The hardware and software must be newly designed specifically for the MU-2-R.

*1 Forward error correction code used for compact discs, hard discs and satellite communications

*2 UART (Universal Asynchronous Receiver Transmitter)

*3 Development kits such as an RS232C interface kit with a D-Sub 9-pin connector (MU2-RIK) are available

■ 1.1.1 Features

- R&TTE compliance (Plan)
- Reliable data communication is possible with strong error correction by Reed-Solomon code.
- Serial data can be transmitted with a simple system of commands.
- Offers a wide communication range with stable operation.
- The transceiver function is incorporated within a compact unit.
- Ideal for battery operated applications thanks to operation at low voltage and low consumption current.
- Uses the UART interface commonly available with on-board CPUs.
- The high frequency circuit is designed specifically as an embedded radio unit, to operate stably on the user system circuit board.
- 1:1, 1:N, and N:N systems can be built by flexibly setting link parameters.
- Long distance communication is possible using a maximum of 10 relay stations.
- It is possible to assess locally the status of radio waves and field noise at the target station and source station.
- Equipped with a standby mode to save the power of systems.
- Field status can be checked in real time using RSSI information in the packet data.
- A function to lower the output power (antenna power) from 10 mW to 1 mW is provided for effective use of radio waves.

■ 1.1.2 Applications

- Serial data transmission
 - Energy monitoring, data monitoring devices, handy terminals, barcode reader, housing equipment control
- Telecontrol
 - Various warning systems, remote control for construction machinery, display devices, motor control, lifters
 - Remote control of FA equipment
- Telemetry
 - Security systems, water level monitors for rivers and dams, temperature and humidity gauges, rain gauges, pressure gauges, voltmeters, ampere meters

1.2 Block Diagram

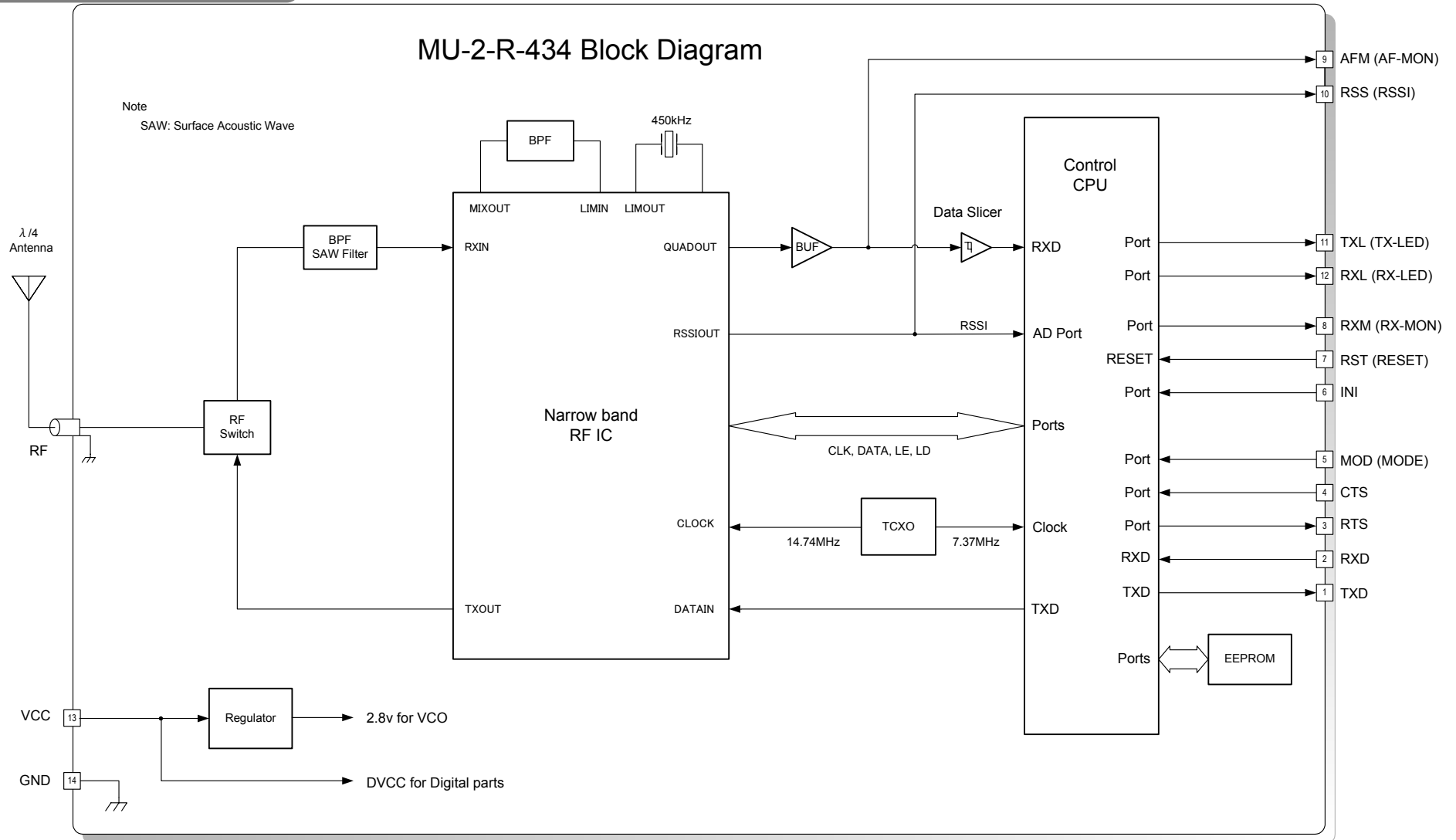

1.3 Example of the Control Method

The VCC terminal of the MU-2-R is connected directly to the power source of the mounted CPU. Ensure that the voltage of the power supply is regulated to within DC +3.0 v to +5.0 v. Basically the MU-2-R uses hardware flow control with RTS or CTS, however 3-line control can be used without the hardware flow control. In this case, set the CTS terminal to Low level. In addition, care is required with the timing of transmitting and receiving.

Example 1 and Example 2 are basically the same methods except for the difference in control voltage.

1.3.1 Example 1: Controlling the MU-2-R with the on-board CPU

It is possible to interface the MU-2-R directly using the UART interface of the on-board CPU.

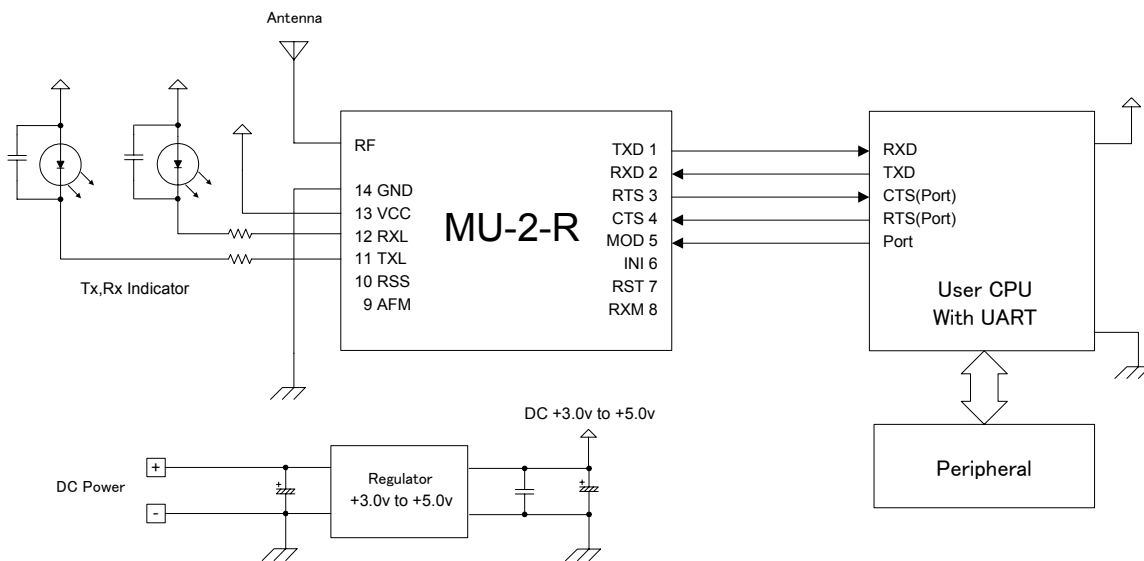

1.3.2 Example 2: Controlling the MU-2-R via RS232C

1. Using the RS232 port of your computer, you can develop a new program for OSs such as Windows and the like. In this case, use an RS232C transceiver. (The program for existing system equipment will not work.)
2. By supplying power to the MU-2-R with a cable, you can also isolate the radio component from your system and locate it in the most suitable environment. The distance can be extended by 15 m to 50 m, but the exact distance should be confirmed through experiments.

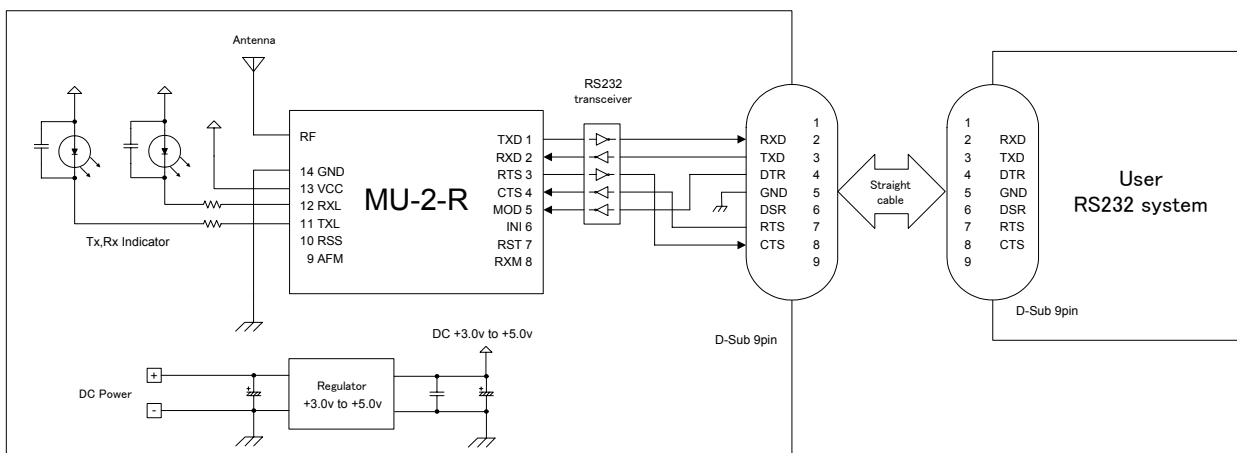

* It is also possible to supply power using the No.1 pin of the D-Sub-connector.

*To use the Evaluation Software Programs, the DSR signal line should be set to High level.

Chapter 2 Specifications and Diagram

2.1 Main Specifications

2.1.1 General specifications

Temperature conditions: +25°C ± 5°C, typical

Item	Specification	Remarks
Compatible standards	(R&TTE Directive EN1999/5/EC)	CE mark(plan)
Emission class	F1D	
Antenna power (selectable)	Within 10 mW +20% -50% or 1 mW	+5°C to +35°C Contact (50 Ω) Selectable by the command
Frequency stability	Within ± 4 ppm	Reference freq. at 25°C
Antenna	1/4λ wire antenna	Gain of 2.14 dBi or less
Communication method	Half-duplex or one-way	
Modulation system	Binary FSK	
Oscillation system	PLL synthesizer system	
Radio communication speed	4800 bps	
Frequency range	433.20000 to 434.7750 MHz	
Channel spacing	25 kHz	
Number of channels	127	Channel step 12.5 kHz
Receiver spurious radiation	-54 dBm or less	
Receiver sensitivity	-110 dBm (Standard protocol) -113 dBm (Error correction protocol)	Packet error rate 0.1% (255 bytes/1 packet)
Operating temperature	-20°C to +65°C (No dew condensation)	The range varies with the temperature conditions.
Storage temperature	-25°C to +70°C (No dew condensation)	
Operating voltage	3.0 V to 5.0 V	Absolute maximum rated voltage 5.5 v
Consumption current	At 10mW: TX 42 mA RX 22 mA At 1 mW: TX 26 mA RX 22 mA	When the supply voltage is 3 v
Standby mode consumption current	2 mA	When the supply voltage is 3 v
Number of EEPROM conversions	100,000 times	Data storage time: About 10 years
Error-correcting system	Reed-Solomon code	RS (255, 247)
External dimensions	36 mm × 26 mm × 8 mm (W × D × H)	Not including the antenna. H is the height from the mounting surface.
Unit weight	14.5 g	

Reference data

* Effective radio communication speed: About 3,400 bps / Conditions: one-way communication, no error correction, 25°C

* Range: About 600 m / Conditions: one-way communication, no error correction, 25°C, line of sight distance, ground level of 1.5 m, vertical antenna

2.1.2 UART interface specifications

Communication method	Serial communication (RS232C format)
Synchronization	Start-stop (asynchronous)
Data speed	1,200 / 2,400 / 4,800 / 9,600 / 19,200 / 38,400 / 57,600 bps
Flow control	RTS/CTS hardware flow control
Other parameters	Data length (8 bits), Parity (None, Even, Odd), Stop bits (1 or 2)

2.2 Terminal Specifications

MU-2 Terminal name, Terminal No. (Top View)

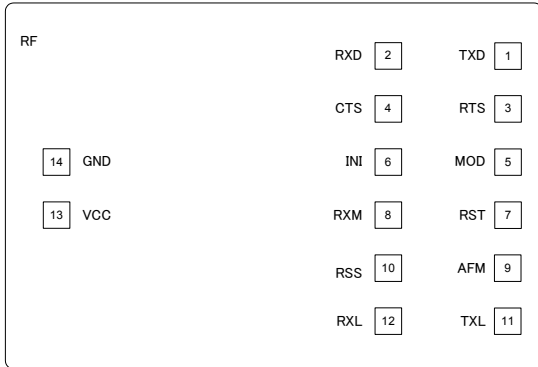

- ◇ The MU-2-R transmits user data in serial data format using the UART input/output port (TXD terminal and RXD terminal).
- ◇ Level conversion is required for connection to RS232. The RS232C DSR signal must be supported by the user's circuit board.
- ◇ The function of each terminal is shown in the table below. Unused terminals should be set to open.
- ◇ The control CPU used with this equipment is a NEC μ PD78F0537GA with a CMOS structure. The thresholds for Low level and High level is $V_{DD} \times 0.2$ and $V_{DD} \times 0.8$ respectively, based on the supply voltage V_{DD} .

Terminal No.	Terminal name	I/O	Description	Internal circuit
1	TXD	O	The serial data transmit terminal.	
2	RXD	I	The serial data receive terminal.	
3	RTS	O	The hardware flow control signal output terminal. If the internal status is not busy, the status is Low and data can be received by the RXD terminal. If the internal status is busy, the status is High and data cannot be received.	
4	CTS	I	The hardware flow control signal input terminal. Determines that the unit is not busy when the status is Low, and sends data from the TXD terminal. Determines that the unit is busy when the status is High, and does not send data.	
5	MOD (MODE)	I	Switches between the command mode, binary mode, or text mode. In the command mode when set to High, and the binary mode or text mode when set to Low.	

Terminal No.	Terminal name	I/O	Description	Internal circuit
6	INI (INITIALIZE)	I	The terminal for initializing the CPU internal settings. The settings are initialized if the power is turned on in the Low state. The default values are enabled when the power is switched on again.	
7	RST (RESET)	I	The CPU reset terminal. Setting this terminal to Low level for a period of 1 ms resets the internal CPU. This should normally be set to open.	
8	RXM (RX-MON)	O	A test terminal for monitoring the internal status with an oscilloscope when receiving data. Normally this should be open and only be used by the manufacturer.	
9	AFM (AF-MON)	O	A test terminal for monitoring the demodulation signal with an oscilloscope. Normally nothing should be connected to this terminal.	
10	RSS (RSSI)	O	The received signal strength indicator output terminal. Normally nothing should be connected to this terminal.	
11	TXL (TX-LED)	O	The terminal for the transmission monitor LED. On when data is transmitted. The signal line includes an internal 1 kΩ resistor. With external resistors, ensure that the LED current is within 1 mA. In addition, add a 470 pF multilayer ceramic capacitor in parallel with the LED.	
12	RXL (RX-LED)	O	The terminal for the receiving monitor LED. On when valid data is received. The signal line includes a 1 kΩ internal resistor. With external resistors, ensure that the LED current is within 1 mA. In addition, add a 470 pF multilayer ceramic capacitor in parallel with the LED.	
13	VCC	I	The power supply terminal. Provide a regulated power source with a supply voltage of DC +3.0 V to +5.0 or less. Applying a voltage higher than the rating will damage the semiconductor of the unit.	
14	GND	I	GND	
-	RF	I/O	The antenna terminal.	

* The terminal specifications may change without prior notice.

2.3 Channel Table

The frequency channels that the MU-2-R can use are channels 1 to 127 in the 434 MHz band. To set the channel, use the command format '@CH + channel number'.

Example: Set channel 15 as the channel to use.
Specify the channel following '@CH' with 2 ASCII (hexadecimal) characters.

Control command: @CH0F_{CrLf}
Control response: *CH=0F_{CrLf}

* : Default channel

MU-2 434MHz					
Channel	Frequency	Channel	Frequency	Channel	Frequency
Dec. (Hex)	MHz	Dec. (Hex)	MHz	Dec. (Hex)	MHz
		20(14)	433.4375	40(28)	433.6875
1(01)	433.2000	21(15)	433.4500	41(29)	433.7000
2(02)	433.2125	22(16)	433.4625	42(2A)	433.7125
3(03)	433.2250	23(17)	433.4750	43(2B)	433.7250
4(04)	433.2375	24(18)	433.4875	44(2C)	433.7375
5(05)	433.2500	25(19)	433.5000	45(2D)	433.7500
6(06)	433.2625	26(1A)	433.5125	46(2E)	433.7625
7(07)	433.2750	27(1B)	433.5250	47(2F)	433.7750
8(08)	433.2875	28(1C)	433.5375	48(30)	433.7875
9(09)	433.3000	29(1D)	433.5500	49(31)	433.8000
10(0A)	433.3125	30(1E)	433.5625	50(32)	433.8125
11(0B)	433.3250	31(1F)	433.5750	51(33)	433.8250
12(0C)	433.3375	32(20)	433.5875	52(34)	433.8375
13(0D)	433.3500	33(21)	433.6000	53(35)	433.8500
14(0E)	433.3625	34(22)	433.6125	54(36)	433.8625
15(0F)	433.3750	35(23)	433.6250	55(37)	433.8750
16(10)	433.3875	36(24)	433.6375	56(38)	433.8875
17(11)	433.4000	37(25)	433.6500	57(39)	433.9000
18(12)	433.4125	38(26)	433.6625	58(3A)	433.9125
19(13)	433.4250	39(27)	433.6750	59(3B)	433.9250

MU-2 434MHz					
Channel	Frequency	Channel	Frequency	Channel	Frequency
Dec. (Hex)	MHz	Dec. (Hex)	MHz	Dec. (Hex)	MHz
60(3C)	433.9375	85(55)	434.2500	110(6E)	434.5625
61(3D)	433.9500	86(56)	434.2625	111(6F)	434.5750
62(3E)	433.9625	87(57)	434.2750	112(70)	434.5875
63(3F)	433.9750	88(58)	434.2875	113(71)	434.6000
64(40)	433.9875	89(59)	434.3000	114(72)	434.6125
65(41)	434.0000	90(5A)	434.3125	115(73)	434.6250
66(42)	434.0125	91(5B)	434.3250	116(74)	434.6375
67(43)	434.0250	92(5C)	434.3375	117(75)	434.6500
68(44)	434.0375	93(5D)	434.3500	118(76)	434.6625
69(45)	434.0500	94(5E)	434.3625	119(77)	434.6750
70(46)	434.0625	95(5F)	434.3750	120(78)	434.6875
71(47)	434.0750	96(60)	434.3875	121(79)	434.7000
72(48)	434.0875	97(61)	434.4000	122(7A)	434.7125
73(49)	434.1000	98(62)	434.4125	123(7B)	434.7250
74(4A)	434.1125	99(63)	434.4250	124(7C)	434.7375
75(4B)	434.1250	100(64)	434.4375	125(7D)	434.7500
76(4C)	434.1375	101(65)	434.4500	126(7E)	434.7625
77(4D)	434.1500	102(66)	434.4625	127(7F)	434.7750
78(4E)	434.1625	103(67)	434.4750	-	-
79(4F)	434.1750	104(68)	434.4875	-	-
80(50)	434.1875	105(69)	434.5000	-	-
81(51)	434.2000	106(6A)	434.5125	-	-
82(52)	434.2125	107(6B)	434.5250	-	-
83(53)	434.2250	108(6C)	434.5375	-	-
84(54)	434.2375	109(6D)	434.5500	-	-

* The number of channels which can be used at the same time in the same area is at most 8 to 11 due to the third-order intermodulation or near-far problem.

2.4 Dimensional Drawing

■ **2.4.1 External dimensions**

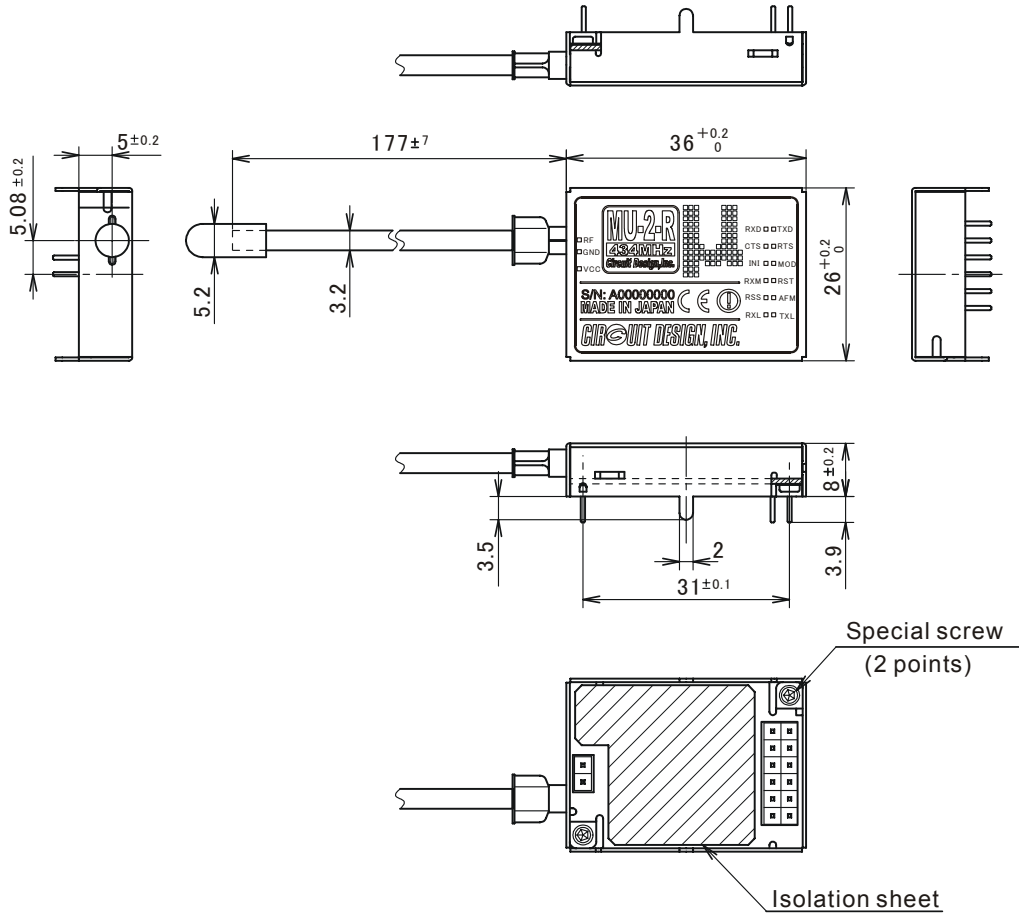

■ **2.4.2 Diagram of dimensions for hole positions**

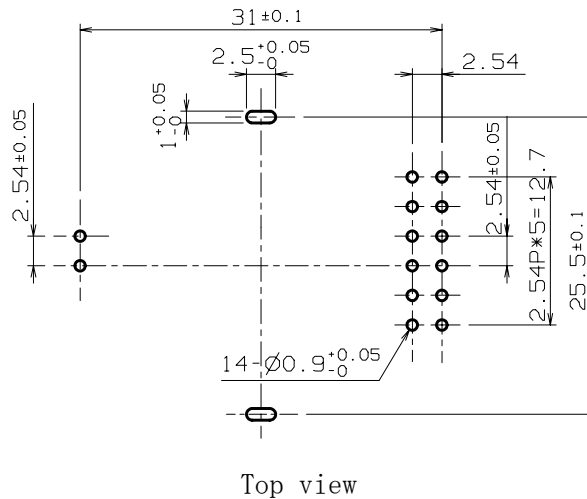

Chapter 3 How to Use the MU-2-R

3.1 Communication Concept

3.1.1 Station types and link parameters

When performing communication using the MU-2-R, the source station transmits data towards the target station. If necessary, it is also possible to relay data using relay stations between. In addition, to avoid collisions with and ensure independence from other systems, it is necessary to set the link parameters to identify the system and each station.

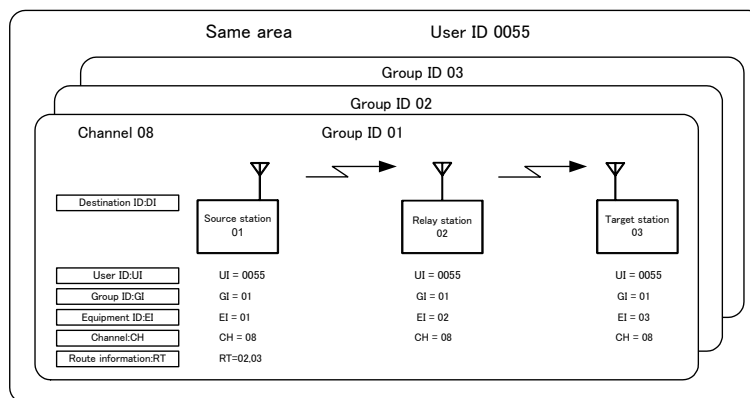

1. The source station, relay station and target station

- **Source station** A station to transmit data
- **Relay station** A station to relay data to the target station. The relay station neither buffer nor resend data but simply relay it directly to the target station. Setting is possible up to a maximum of 10 relay stations.
- **Target station** A station to receive data. The target station outputs the received data to the user controller. It also sends ACK data and RSSI (received signal level) data to the source station depending on the command issued from the source station.

2. The link parameter

In order to establish communication between the radio stations, it is necessary first to set the link parameters.

• UI: User ID

An ID given to the MU-2-R user for identification of the user.

If all the equipment within the user system is not set to the same User ID, no link will be made.

• GI: Group ID

An ID to identify the group within the user system. Set the same Group ID for all radio stations within the group.

• EI: Equipment ID

An ID specified to each equipment for identification of each station. The data transmit command transmits data to the Equipment ID set as the route information or Destination ID

• DI: Destination ID

Specifies the Equipment ID of the target station when no relay station is used in the system.

• RT: Route information

Route information to the target station in the system using relay stations. List the route information in the route register or transmit command character string.

• Channel

If all stations in the same system are not set to the same channel, no link will be made.

■ 3.1.2 Basic data transmission

When user data is transmitted from the source station towards the target station using data transmit commands, a character string including the data (data receive) is output from the target station and processed by the program of the user controller.

Example 1 1:1 (1:N) system not using the relay function

When the source station 5F transmits the 5 byte of data 'ABCDE' to the target station 01. The diagram below shows the case in which the data transmit command 1 is issued.

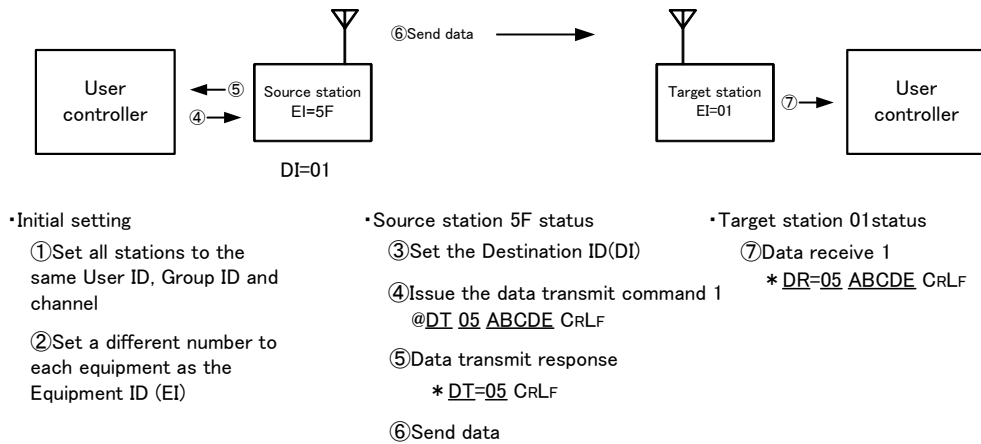

Example 2 System using the relay function

When the source station 5F transmits the 10 byte of data '0123ABC\$#4' to the target station 8F via relay stations 01, 02 and 03.

With 1:N communication not using relay stations, the route is specified using the Destination ID command '@DI' at the source station, however when relay stations are used, data can be relayed using one of the following.

1. Set the route information in the route register using the '@RT' command to specify the relay route.
2. Enter the route information directly at the end of the data transmit command '@DT'.

When performing two way communication, it is necessary to confirm if the data transmitted from the source station is received at the target station without error. The MU-2-R has the data transmit command which requests the target station to return data receive acknowledgment 'ACK'. The diagram below shows the case in which relay stations are used and the data transmit command 2 with ACK is issued.

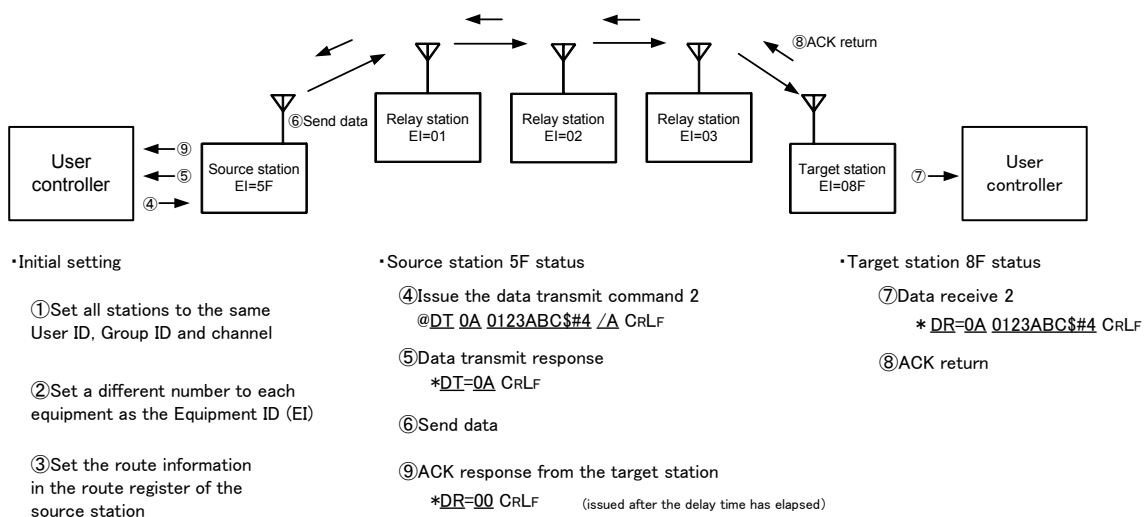

■ 3.1.3 The data transmit command

The MU-2-R has 3 data transmit commands.

1. Data transmit command 1
2. Data transmit command 2
3. Data transmit command 3

The user can freely decide the format for the data part of the data transmit command. Using the data transmit command 3, the received signal level of the received packet data is included at the front of the receiving data (data receive), which is useful to determine the transmission route and so on.

The same can be done with the data transmit command 2 by setting the '@SI' command.

When actually developing a system program, in addition to the transmission process of the user system data such as temperature data and display data, it is necessary to perform various controls. By choosing the transmit command to use depending on the system configuration, it is possible to simplify designing of the system protocol and make an easy-to-use program.

1. Data transmit command 1

A most basic transmission command mainly used for 1:1 (1:N) systems not using relay stations.

2. Data transmit command 2

A data transmit command for systems using relay stations. It is also possible to be used for 1:1 (1:N) systems not using relay stations.

Command option character for the data transmit command 2: '/'

Target station output characters (Data receive): '*DR'

3. Data transmit command 3

A data transmit command for systems using relay stations. It is also possible to be used for 1:1 (1:N) systems not using relay stations.

The received signal strength (RSSI) of the received packet data is included at the front of the data receive at the target station.

Command option character for the control transmit command 3: '%'

Target station output characters (Data receive): '*DC'

With the data transmit command 2 and 3, the method of command notation on the program is different depending on the following cases.

1. Transmission based on route information preset in the route register.
2. Transmission based on route information directly entered in the transmit command.

Example: Transmission using the data transmit command 3

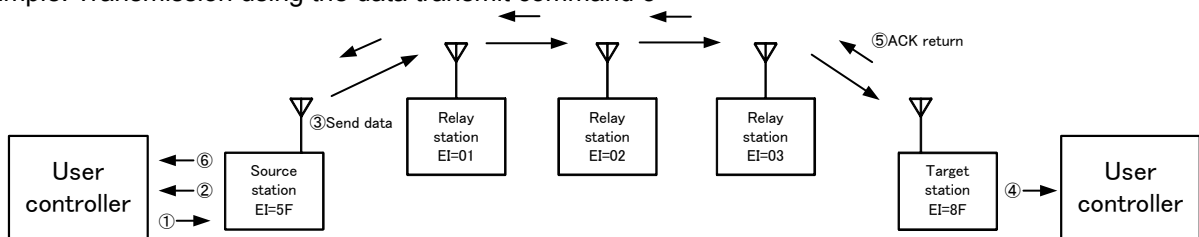

•Source station 5F status

- ① Issue the data transmit command 3
Format 1: @DT 0A 0123ABC\$#4 %A 01.02.03.8F CRLF
Format 2: @DT 0A 0123ABC\$#4 %A CRLF
- ② Data transmit response
*DT=0A CRLF
- ③ Send data
- ⑥ ACK response
*DC=45 00 CRLF (issued after the relay time has elapsed)

•Target station 8F status

- ④ Data receive 3
When RI=OF *DC=45 0A 0123ABC\$#4 CRLF(Default)
When RI=ON *DC=45 0A 0123ABC\$#4 /A 5F.01.02.03 CRLF
- ⑤ ACK return

Transmit the 10 bytes (0Ah) of data '0123ABC\$#4' to the target station ID = 8F via the relay station IDs = 01, 02, 03. The source station Equipment ID = 5F.

* '45h' at the front indicates the signal level of the received packet. In this case, it is -69 dBm (45h).
For details of the value, refer to the 'RA' command.

■ 3.1.4 The link parameters

In order to transmit and receive data, the MU-2-R has the following link related parameters.

Link parameters can be specified easily with commands, and they can be changed each time data is sent.

In addition, if the source station, relay station, and target station do not all use the same channel, no link will be made.

1. UI: User ID, 16-bit, 0000h to FFEh (0000h is the ID for testing, and FFFFh cannot be used)

The User ID is an ID given to the MU-2-R user for identification of the user system. Communication is not possible unless all equipment within the user system is set with the same User ID. If a user configures multiple systems, use the Group ID for identification. The User ID setting command is '@UI' + User ID + password'. The product default User ID is 0000 and this can be used as it is when no particular User ID is required. However, we recommend that you set a User ID to prevent radio interference within a given area. If you require a User ID, please contact Circuit Design, Inc. The 16 User IDs listed in the explanation of User ID command can be used freely.

2. GI: Group ID, 8-bit, 00h to FFh

The Group ID is an ID to identify the group within the user system. Set the same Group ID for all equipment within the group. Maintain Group IDs as identification numbers when building other systems. The setting command is '@GI'.

Please contact Circuit Design, Inc. in cases where use of Group IDs is insufficient and you require other User IDs.

3. EI: Equipment ID, 8-bit, 01h to FFh (FFh is a special operation)

The Equipment ID is an ID for identification of each radio equipment. At the source station, enter the Equipment ID of the target station at the end of the route information or as the Destination ID to transmit data.

At the target station, the Destination ID included in the received packets is automatically compared with the local station EI. The setting command is '@EI'.

4. DI: Destination ID 8-bit, 00h to FFh (00h and FFh are special operations)

This is used to specify the Equipment ID of the target station in the system not using relay stations. The setting command is '@DI'. If 00 (DI = 00h) is specified as the Destination ID and data transmit command 1 is issued, all equipment within the same group will receive the data at the same time, irrespective of the Equipment ID (Broadcast). If DI = FFh is specified, the data is sent but no station will receive it.

5. RT: Route information

This indicates the route to the target station.

The route information lists the Equipment IDs of the relay stations and the Equipment ID of the target station in the route register or data transmit command character string. The route information is used with the data transmit command 2 and 3, and there are two ways to transmit data as follows.

- Transmission based on route information set in the route register with the '@RT' command
- Transmission with the route information entered directly in the data transmission command

If only one station is specified in the route information, the station will be the target station.

6. Channel

If all stations in the same system are not set to the same channel, no link will be made.

■ 3.1.5 Conditions for establishing a link

A link is established for communications when the following conditions are met simultaneously.

1. There are no errors in the received packet
2. The User ID and Group ID match
3. The Equipment ID specified in the route information or Destination ID and the Equipment ID of the target station match
4. The channel used is the same

3.2 System Configuration (When the Relay Function is Not Used)

The MU-2-R can be used for building 1:1, 1:N, and N:N systems. Several systems can be operated within the same area by separating the channels used.

Equipment IDs from 01h to FEh can be specified, and a maximum of 254 MU-2-R units can be connected in 1 group. With 1:1 (1:N) communication, the Destination ID is specified and data is transmitted with the data transmit command 1, however in this case set the route register to "relay function disabled = 'NA'" using the '@RT' command.

3.2.1 Communication within a group (1:N and N:N systems)

Set the same User ID and Group ID for one group. If the Destination ID specified at the source station and the Equipment ID of the target station match, data (data receive) is output from the target station.

The diagram below shows a 1:N system, although it is also possible to build an N:N system in which all the units have an equal relationship.

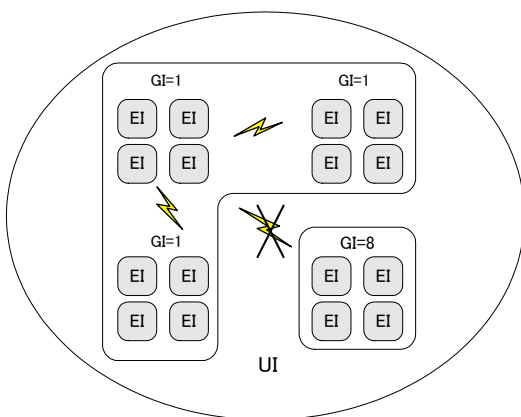

Item name		Size	ID value	Content
UI	User ID	2bytes	0000~FFFE	Set a password
GI	Group ID	1byte	00~FF	No. 0 to 255
EI	Equipment ID	1byte	01~FE	No. 1 to 254

※Group ID and Equipment ID can be set freely within the range above.

※All equipment in the system has the same frequency channel.
 ※Communication is not possible between different Group IDs.

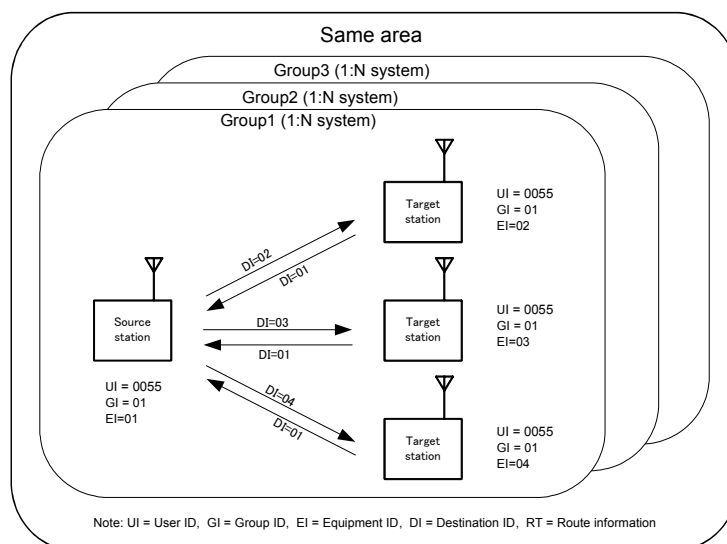

Note: UI = User ID, GI = Group ID, EI = Equipment ID, DI = Destination ID, RT = Route information

◇Communication between groups

By changing the Group ID for transmitting, it is possible to communicate with another group.

◇Broadcast communication

If the Destination ID is specified as 00h at the source station and data is transmitted, all target stations will receive the data at the same time, irrespective of the Equipment ID.

3.3 System Configuration (When the Relay Function is Used)

With 1 hop communication, the Destination ID is used as a link parameter, however with multi-hop communication using the relay function, data is transmitted based on the route information set in the route register with the '@RT' command or based on route information entered directly in the '@DT' command. When using the relay function, use the data transmit command 2 or 3.

The MU-2-R relay function does not perform retry between each station for data. The data from the source station is transmitted at once through to the target station. When reliability is required for data transmission, use the '@DT' command (/A, /B, %A, %B command options) that has an ACK response. It is possible to set a maximum of 10 relay stations.

3.3.1 Transmission with the route register route information

The diagram below is an example of transmission based on route information set in the route register. Route information is set only in the source station. In this case, use only the command option '/A' or '%A' for the '@DT' command.

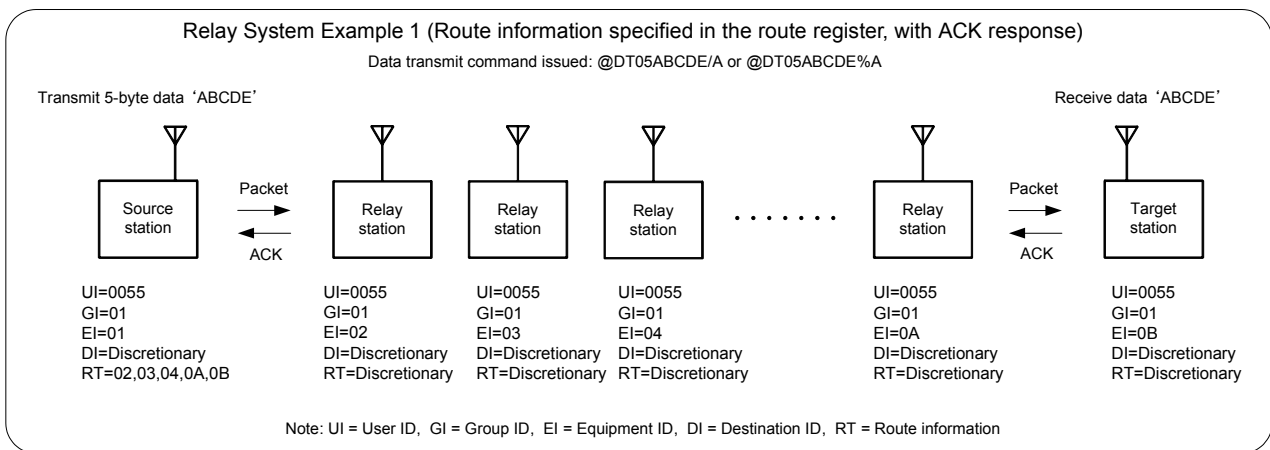

3.3.2 Transmission with the route information entered in the transmit command

The diagram below is an example of transmission with the route information entered directly in the command option line of the '@DT' command. Enter the route information in the '@DT' command issued after '/A' or '%A'. In this case, the route information set in the route register is ignored.

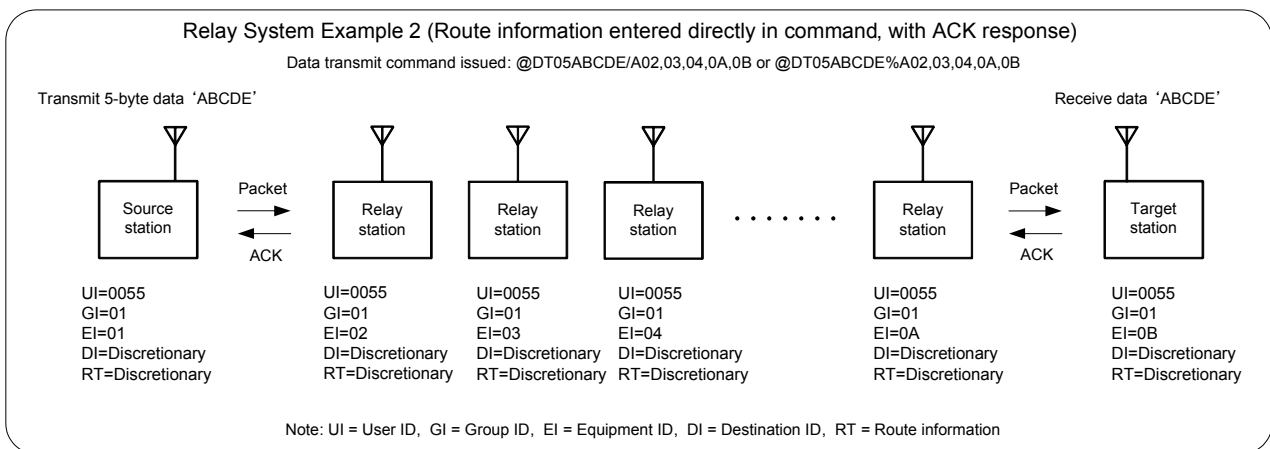

■ 3.3.3 1:N relay system

The diagram below shows a 1:N system using the relay function, in which communication is performed with several target stations at a remote location. In the diagram, the route information is entered directly in the transmit command, however communication is also possible using the route register content.

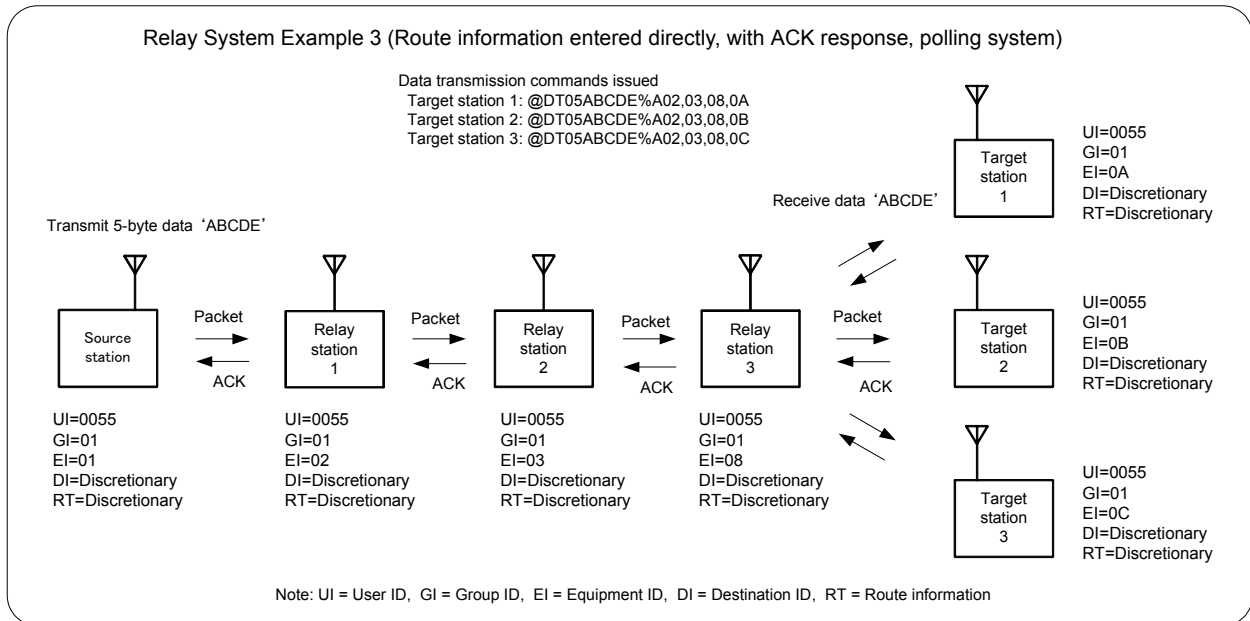

Broadcast communication

If data is transmitted after Equipment ID = 00h as the last number in the route of the source station route information settings, all target stations will receive the data at the same time, irrespective of the Equipment ID. The command for the system in the diagram above is as follows.

Control transmit command 3: @DT 05 ABCDE %R 02,03,08,00

However, note that the data is transmitted in a range to which the radio waves reach from the last relay station (relay station 3). In other words, relay station 2 also receives the data at the same time. Also, do not use commands with ACK responses (command options: /A, /B, %A, and %B) in the transmit command since these cause radio wave collisions.

3.4 Modes

The MU-2-R has the following 3 modes.

1. Command mode (standard mode)
2. Text mode (for testing)
3. Binary mode (for testing)

Transmitting and receiving data is usually performed in the command mode. Use this mode when you build your system. The text mode and binary mode are provided as testing modes, however you can also make applications within the range of these functions.



Note

When configuring your system, ensure that the source station and target station are in the same mode. In addition, ensure that the relay function is used in the command mode.

■ 3.4.1 Command mode

This is the basic mode for sending and receiving user data by radio.

The MU-2-R commands consist of commands for transmitting and receiving data, and commands for control of the parameters of the MU-2-R unit itself. Changing the parameters, mode, and channel of the main unit cannot be performed in the binary mode or text mode. Consider how to enable mode switching at the hardware design stage. Control of the radio component is performed automatically by the MU-2-R, so you do not need to pay attention to this aspect.

255 bytes of user data can be sent at one time.

It is convenient to use the data transmit commands 1 and 2 for transmission of user system data and the data transmit command 3 if control is needed to transmit the data. The user can freely decide the format of those transmit commands.

With the transmit command 2 and 3, it is possible to request to return an 'ACK signal' to show that the data is correctly received at the target station. In addition, it is possible to output the same data from the relay station as from the target station. This makes it possible to synchronize the system.

When the MU-2-R receives data, since only correctly received data is output to the user application as a data receive, it is processed on the user side properly.

■ 3.4.2 Text mode (for testing)

This mode is used to check operation using RS232C communication software (HyperTerminal and the like) on a PC.

Text data can be input and output directly. This mode is convenient for transmitting and receiving characters entered using a keyboard. Always add the `CR LF` code as a terminator at the end of the character string. When the MU-2-R detects this terminator, it starts data transmission. Ensure that the maximum number of characters input is within 255 bytes. The `CR LF` code (0Dh, 0Ah) and Esc code (1Bh) cannot be sent by radio. However, the `CR LF` code is attached to the end of the data output from the target station as a terminator.

■ 3.4.3 Binary mode (for testing)

This mode is used to check operation using RS232C communication software (HyperTerminal and the like) on a PC.

All 8-bit codes (00h to FFh) can be transmitted and received as data. 225 bytes of binary data can be input or output directly at one time.

The input character string (max. 255 characters) is buffered until the buffer is filled with 255 characters, or until the value set for the period during which no data is input is reached, and the character string is framed and transmitted. The setting for the period during which no data is input is performed with the '@TB' command.

■ **3.4.4 Mode setting**

When the MODE terminal is at High level

The MU-2-R is set to the command mode irrespective of the setting in the mode register. The recommended operation mode of the MU2-R is the command mode. When setting the MODE terminal to Low to switch to other modes, preset the mode register.

When the MODE terminal is at Low level

1. In the command mode if the '@MDTX' command is issued, the MU-2-R mode register is set to 'TX', which is the text mode. Issuing the ESC code returns from the text mode to the command mode.

2. In the command mode if the '@MDBI' command is issued, the MU-2-R mode register is set to 'BI', which is the binary mode. To switch from the binary mode to the command mode, turn off the power supply of the MU-2-R briefly or reset the hardware.

If the BI mode is fixed in the EEPROM using the command option '/W', the MU-2-R cannot be set to the command mode without initializing it.

To initialize the MU-2-R, set the INI terminal to Low and turn on the power, and after turning off the power briefly, set the INI terminal to High and turn on the power again.

3. By setting the MODE terminal to High level, the MU-2-R can be set to the command mode whatever the setting in the MU-2-R mode register (irrespective of the current mode).

Mode relationship diagram

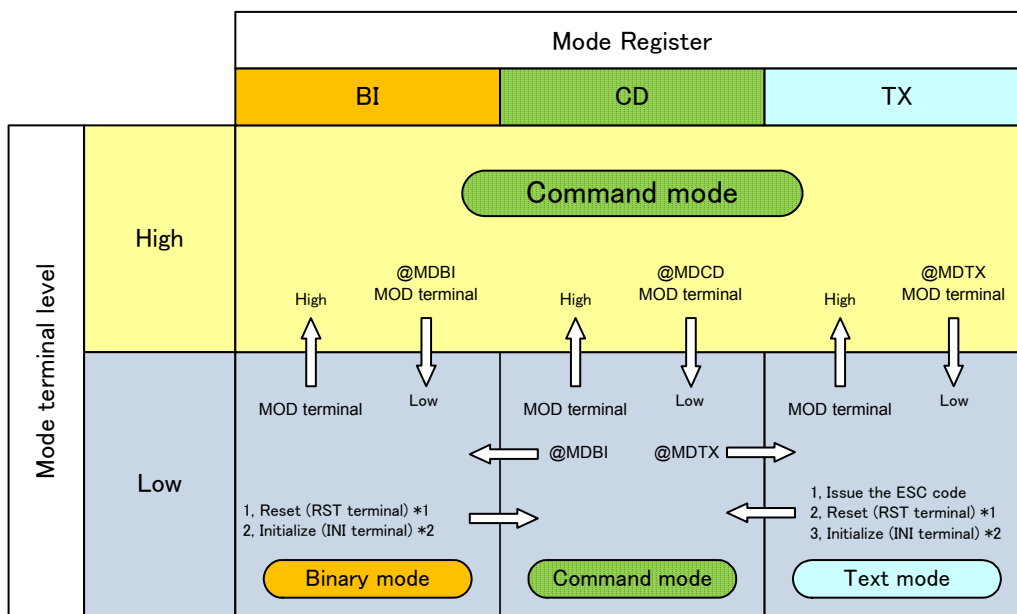

*1: When the mode is set in the RAM *2: When the mode is fixed in the EEPROM

* **BI:** Binary mode **CD:** Command mode **TX:** Text mode

* The brackets () in the diagram indicate use of an RS232C driver. When using HyperTerminal, the DTR line is always at H level and the MODE terminal is at L level.

3.5 Resetting

If you are uncertain about the various settings of the MU-2-R, return them to the settings at the time the power is turned on.

- ◆ The internal CPU is reset by any of the following.
 1. Set the reset (RST) terminal of the MU-2-R to 1 ms period Low level.
 2. Issue the software reset command '@SR'.
 3. The target station can be reset using an extended command.

3.6 Initializing

Return the unit to the factory default settings if communication with the MU-2-R is not possible or if you are uncertain of the internal settings.

- ◆ The internal CPU is initialized with any of the following.
 1. Set the INI terminal of the MU-2-R to Low level and turn on the power. Then turn off the power, and after setting to the INI terminal to open, turn it on again.
 2. Issue the initialize command '@IZ'. After issuing it, always issue the software reset command '@SR'.
- ◆ After initialization the main parameter values (default values) are as follows. For details of the default values, refer to each command in the manual.

1. Link parameters
User ID: UI = 0000, Group ID: GI = 00, Equipment ID: EI = 01, Destination ID: DI = 01, Channel = 1 channel
2. UART parameters
Baud rate = 19,200 bps, parity = none, stop bit = 1
3. Internal operation parameters
Mode = command

3.7 Changing Channels

It is possible to change the channels used when the system is in operation.

This can be done by changing the channels of specified target station individually, or by changing the channels of all stations specified in the route information at once.

The channel changing function uses radio commands. Before changing the channel, always check that a data link is possible. However, since wireless errors may also occur in this case, changing the channel may not always be possible. Exercise prudence when changing channels.

3.8 Standby Mode

The MU-2-R is equipped with a standby mode to save the power of systems. To switch to the standby mode, issue the '@SY' command. The MU-2-R is set to the standby mode immediately after the command is received.

There is no response to this command. After issuing the standby command, set the RXD, CTS, MODE, INI, RESET terminals to High level. Once switched to the standby mode, the TXD, RTS, RX-MON, TX-LED, RX-LED terminals are set to High level. In addition, the setting information set until immediately before switching to the standby mode is retained as it is and still effective after returning to the normal mode.

To return from the standby mode to the normal mode, set the CTS signal line (RTS signal line on the control side) from High level to Low level.

MU-2-R 434MHz		
	Consumption current	Recovery time
Standby mode	2 mA (at 3 V power supply)	65 ms

3.9 Antenna power setting

The MU-2-R is equipped with an antenna power switching function which can lower the antenna power (output power) from 10 mW to 1 mW. When performing communication in a small area, setting to 1 mW makes it possible to share radio wave resources effectively with many systems. To lower the power, issue the '@PW' command.

3.10 Communication Protocols

The MU-2-R has a standard protocol and error correction protocols as communication protocols. Among the error correction protocols, the interleave method has stronger error correction ability.

1. Standard protocol: a protocol normally used when error correction is not performed.
2. Error correction protocol: Communication with error correction by Reed-Solomon code.
3. For error correction protocols, there are three types of protocol - 'without interleave' 'with interleave 1' and 'with interleave 2'.

* To set the communication protocol to the error correction protocol (error correction on), set to 'ON' 'I1' or 'I2' using the '@EC' command with '/W' command option.

* The standard protocol is a protocol used when the error correction protocol is off.

◆ The error correction protocol

An error correction function with Reed-Solomon codes which corrects errors on the receiver side.

Reed-Solomon codes are effective in the environment where burst errors occur and reliable communication is required. In conventional communication systems, if error occurs in the sent data between radios, the sent packet has to be discarded and a new packet has to be sent, but using error correction protocols for communication, the number of retry can be considerably reduced. However note that the communication speed is lowered due to the internal processing with the error correction function. Use the standard protocol if radio communication speed is required.

Effective radio communication speed (actual measurement value when transmitting 8352 bytes)

1. Standard protocol: 3400 bps
2. Error correction protocol (without interleave): 2300 bps



Note

*Basically communication is only possible between the same protocols.

Chapter 4 Commands, Responses and Receives

4.1 About the command, Response and Receive

When the source station MU-2-R receives a command from the user controller, it returns a command response to the user controller as an acknowledgment of command receipt. At the same time, it performs processing corresponding to the command. The commands, responses and receives the MU-2-R uses are as follows.

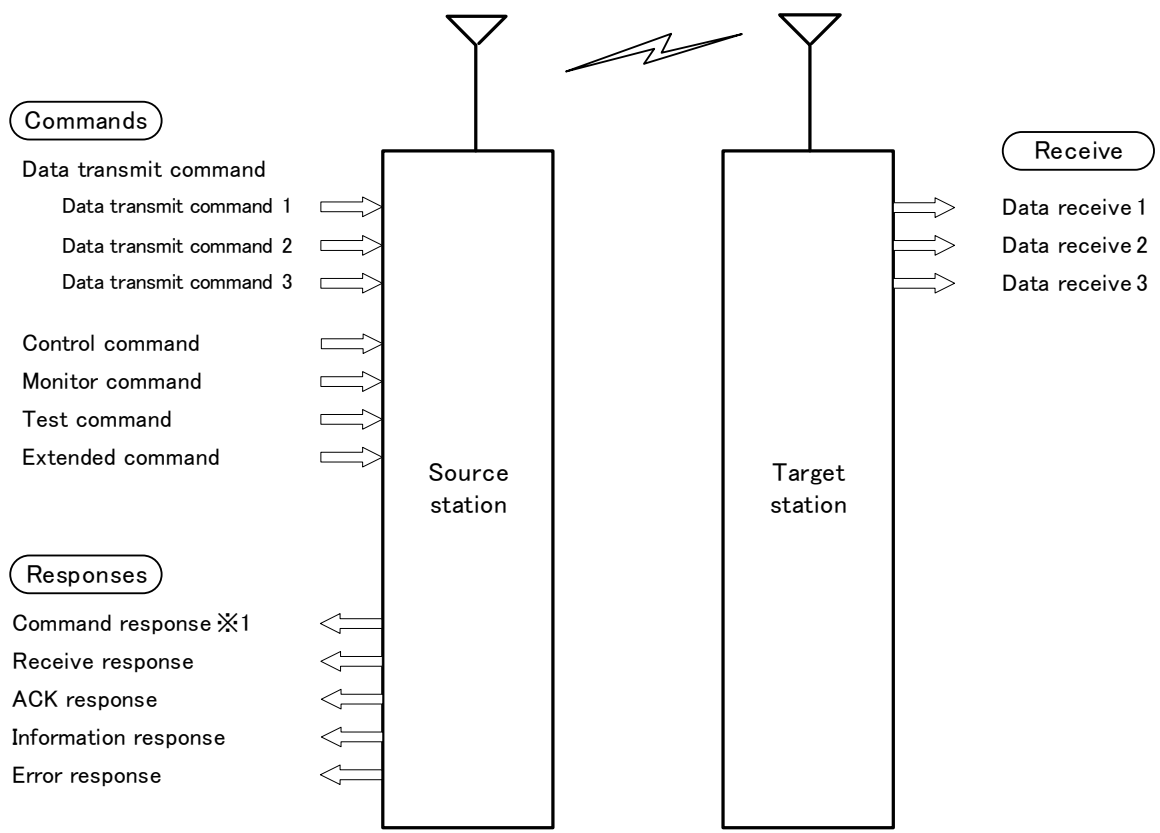

- ※1 Command response types
- Data transmit response •Control response •Monitor response
 - Test response •Extended response

* The command response is a command receipt response corresponding to the issued command.

Command issued	Command responses
Data transmit command	→ Data transmit response
Control command	→ Control response
Monitor command	→ Monitor response
Test command	→ Test response
Extended command	→ Extended response

1. Data transmit command, data transmit response and data receive

The data transmit commands are commands to transmit user data from the source station. The target station outputs a data receive corresponding to the data transmit command issued. There are three types of transmit command - data transmit command 1, data transmit command 2 and data transmit command 3.

Example 1 Data transmit command 1 (For 1:1 and 1:N systems)

It is also possible to receive an ACK response.

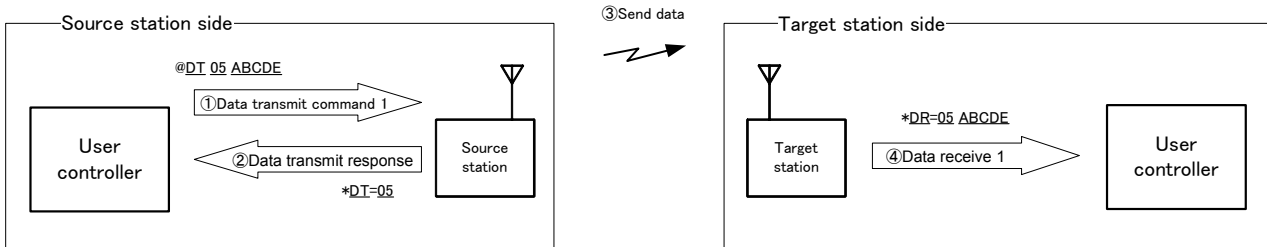

Example 2 Data transmit command 2 (Using the relay function, with ACK, route information specified in the route register)

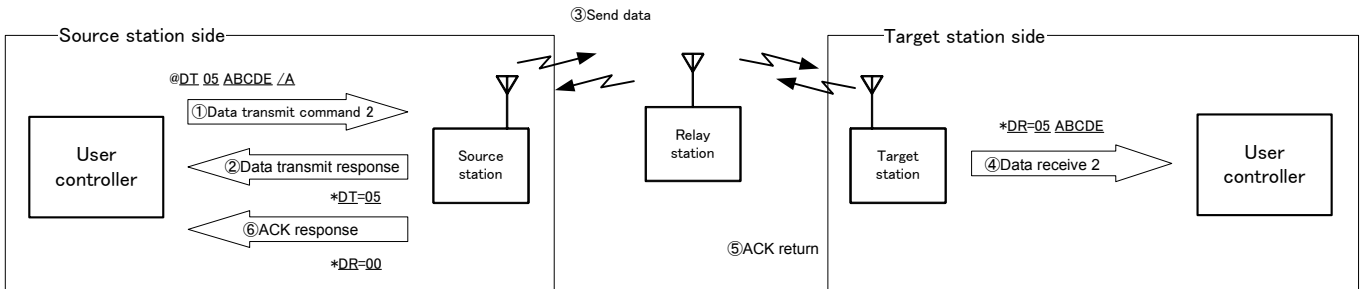

Example 3 Data transmit command 3 (Using the relay function, with ACK, Route information entered in command)

RSSI information is included at the front of the data receive. The RSSI level of the signal received at the target station is included at the front of the ACK response.

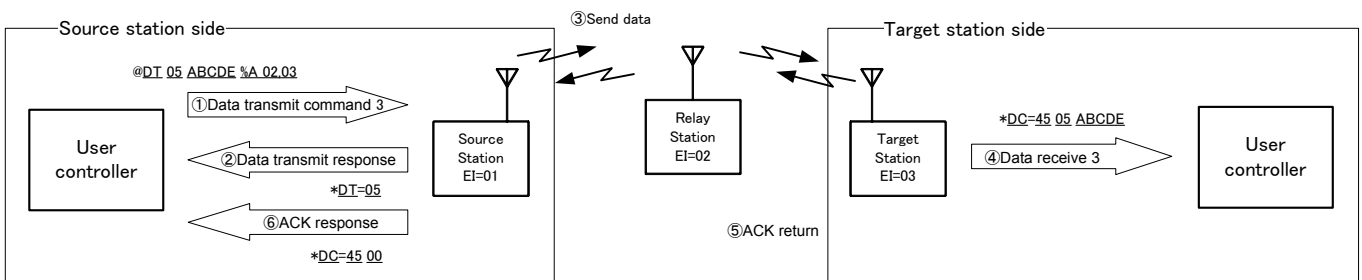

2. Control command and control response

Commands and responses to control the various operations of the MU-2-R.

Example Change CH to 30(1Eh)

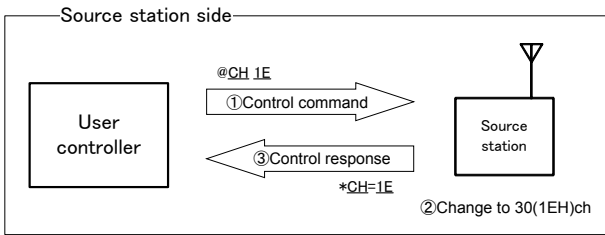

3. Monitor command and monitor response

Commands and responses to perform the various monitoring functions.

Example With no receive response

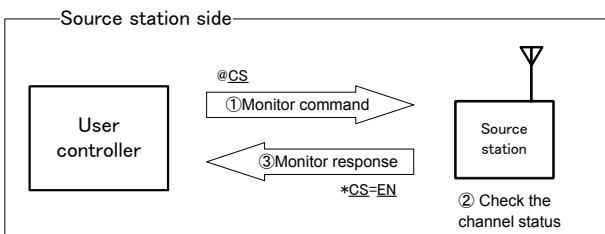

Example With receive response

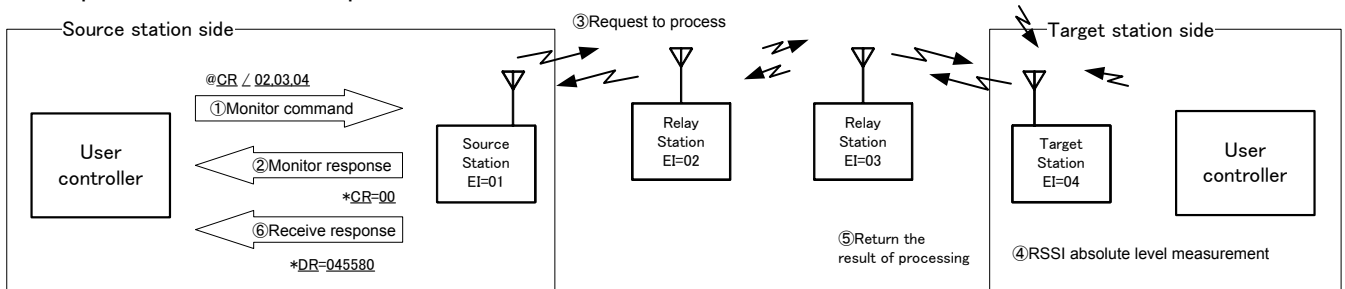

4. Test command and test response

A command and response to perform the various test functions.

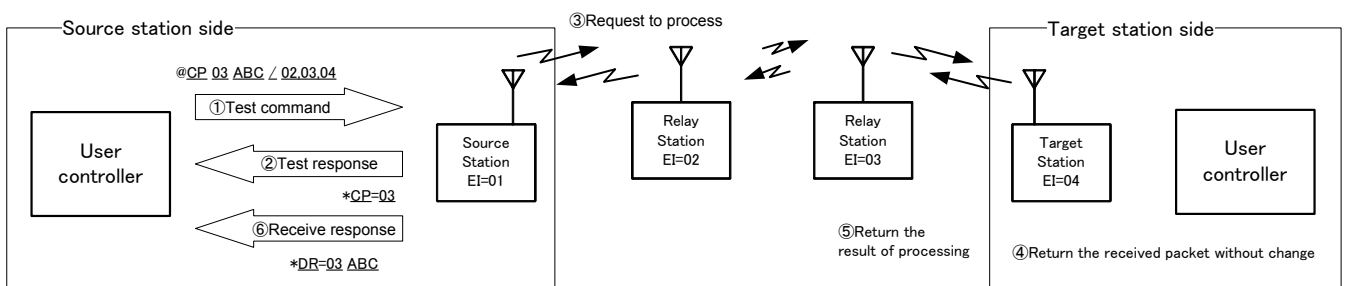

5. Extended command and extended response

Commands and responses to perform the extend functions.

Example Change the CH of the target station to 07

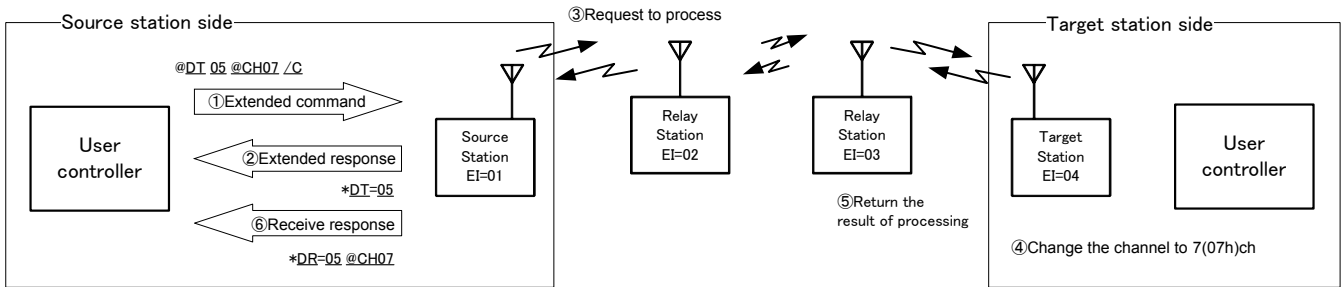

6. Receive response

When issuing the monitor command and extended command, processing is performed at the target station and the result is returned to the source station. This processing result is output from the source station as a receive response.

7. ACK response

When issuing the extended command and so on, an 'ACK' is returned to show the target station receives the command. This 'ACK' is output from the source station as an ACK response.

8. Information response

Information response is a response output from the MU-2-R unit itself.

9. Error response

A response returned if there are errors in the format of the transmit command, control command and so on.

4.2 Command, Response and Receive Table

* In the table below, xx and XX, and XXXX are 2 and 4 digit hex values respectively. w indicates ASCII characters or byte data.

4.2.1 Data transmit commands and data transmit responses

Command name	Command format	Data transmit response format (Command response)	Reference page
Data transmit command 1 (no relay function)	@DT XXww...ww	*DT=XX	
Data transmit command 2 (Relay function, no ACK)	@DT XXww...ww/R ※1	*DT=XX	
Data transmit command 2 (Relay function, ACK)	@DT XXww...ww/A ※2	*DT=XX	
Data transmit command 3 (Relay function, no ACK)	@DT XXww...ww%R ※3	*DT=XX	
Data transmit command 3 (Relay function, ACK)	@DT XXww...ww%A ※4	*DT=XX	

*1, 2: There are options /S and /B that output data at relay stations.

*3, 4: There are options %S and %B that output data at relay stations.

4.2.2 Data receives

A receiving data output from the target station.

Note that the data receive character string depends on the data transmit command issued from the source station.

Receive name	Receive format	Corresponding command	Reference page
Data receive 1	*DR=XXww...ww ※1	Data transmit command 1 (@DT)	
Data receive 2	*DR=XXww...ww ※1	Data transmit command 2 (@DT.../)	
Data receive 2 (With RSSI information)	*DS=xxXXww...ww ※2	Data transmit command 2 (@DT.../)	
Data receive 3	*DC=xxXXww...ww	Data transmit command 3 (@DT...%)	

*1: When the mode setting with RF received signal level information SI is OF.

*2: When the mode setting with RF received signal level information SI is ON.

■ **4.2.3 Control commands and control responses**

Command type	Command name	Command format	Control response format (Command response)	Reference page
Radio link related setting and acquisition commands	User ID setting	@UI XXXX,XXXX	* UI=XXXX	
	Group ID setting	@GI XX	* GI=XX	
	Equipment ID setting	@EI XX	* EI=XX	
	Destination ID setting	@DI XX	* DI=XX	
	Relay route designation	@RT XX,XX,...,XX	* RT=XX,XX,...,XX	
	Channel setting	@CH XX	* CH=XX	
UART parameter setting commands	UART baud rate setting	@BR ww	* BR=ww	
	UART parity setting	@PB ww	* PB=ww	
	UART stop bit setting	@SB ww	* SB=ww	
Operation setting and information acquisition commands	Operation mode setting	@MD ww	* MD=ww	
	Command mode input waiting time setting	@TC XX	* TC=XX	
	Time without input in the binary mode setting	@TB XX	* TB=XX	
	Attach route information mode setting	@RI ww	* RI=ww	
	Response display mode setting	@RM ww	* RM=ww	
	Program version acquisition	@VR	* VR=XXww...ww	
	Serial number acquisition	@SN	* SN=xxxxxxxxxxxx	
	Reset	@SR	* SR=00	
	Initialize	@IZ	* IZ=00	
	Standby mode setting	@SY XX	No response	
	Mode setting with RF received signal level information	@SI ww	* SI=ww	
	Receive route information use setting	@RR ww	* RR=ww	
	Antenna power setting	@PW ww	* PW=ww	
Error correction protocol setting *1	@EC ww	* WC=ww		

*1: The protocol used when the error correction protocol is off is defined as a standard protocol.

■ **4.2.4 Monitor commands and monitor responses**

Command name	Command format	Monitor response format (Command response)	Response type	Reference page
Channel status acquisition	@CS	* CS=ww	No response	
RSSI absolute level measurement	@RA	* RA=XX	No response	
Target station all channel RSSI absolute level measurement	@CA	* CA=00	Receive response	
Target station RSSI absolute level measurement	@CR	* CR=00	Receive response	
All channel RSSI absolute level measurement	@RC	* RC=XX...XX	No response	

*RSSI : Received Signal Strength Intensity

4.2.5 Test commands and test responses

Command name	Command format	Test response format (Command response)	Response type	Reference page
Test data continuous transmission	@CT ww	*CT=ww	No response	
Packet test	@CP XXww...ww	*CP=XX	Receive response	

4.2.6 Extended commands and extended responses

Command function	Command format	Extend response format (Command response)	Response type	Reference page
<ul style="list-style-type: none"> • Target station channel change • Fixing the change in internal EEPROM 	@DT05@CHXX/C @DT07@CHXX/W/C	*DT05 *DT07	ACK response	
<ul style="list-style-type: none"> • Multiple station channel change • Fixing the change in internal EEPROM 	@DT05@CHXX/F @DT07@CHXX/W/F	*DT05 *DT07	Control response	
Target station test data issue	@DT05@CTXX/C	*DT05	ACK response	
Target station reset	@DT03@SR/C	*DT03	ACK response	
Resetting multiple stations at ones	@DT03@SR/F	*DT03	Control response	

4.2.7 Receive response

When issuing the monitor command and extended command, processing is performed at the target station and the result is returned to the source station. This processing result is output from the source station as a receive response. The content of the receive response depends on the command issued. For details, refer to the explanation of each command.

4.2.8 ACK response

When issuing the extended command and so on, an 'ACK' is returned to show the target station receives the command. The 'ACK' is output from the source station as an ACK response. The content of the ACK response depends on the command issued. For details, refer to the explanation of each command.

4.2.9 Information response

Information response is a response output from the MU-2-R unit itself.

4.2.10 Error response

A response returned if there are errors in the format of the transmit command, control command and so on.

4.3 Save Setting Command Options

By specifying the option '/W' as continuation of a command, command values can be fixed in the EEPROM within the MU-2-R. The next time the power is turned on, the contents of the EEPROM are set to the initial values. The time required for conversion is 55 ms.

The commands that can specify the option '/W' are as follows.

BR, CH, CT, DI, EC, EI, GI, MD, PB, PW, RI, RM, RR, RT, SB, SI, TC, TB, UI

Example: Fix the User ID as 0000h (UI=0000 is for testing)

Control command: @UI 0000,0B27 /W CrLf
 Control response: *WR=PS CrLf
 *UI=0000 CrLf

Example: Sets the channel to ch 16 and fix it.

Control command: @CH 10 /W CrLf
 Control response: *WR=PS CrLf
 *CH=10 CrLf



Note

1. The command parameter is applied immediately after the command to change it is issued. In particular, note that if the UART related parameters are changed, communication will not be possible unless the UART parameters on the control side are changed.
2. The number of EEPROM conversion is 100,000. Do not design a program which needs to be rewrote repeatedly.
3. Do not issue other commands during conversion of the EEPROM.

4.4 Command, Response and Receive details

The default value In the explanation below, “Default” value is the factory setting set using the ‘INI’ terminal or by issuing the initialize command.

The terminator In the explanation below, the terminator which is the characters that indicate the end of the command and response is the symbol ‘CRLF’. ‘CRLF’: CR (carriage return: ‘CR’ = 0Dh) + LF (line feed: ‘LF’ = 0Ah)

4.4.1 Data transmit commands, responses and data receives

Data transmit command basic format

Prefix + command name + value + data + command option + terminator

Prefix: ‘@’=40h, a code that indicates the start of the command string.

Command name: The 2 ASCII characters ‘DT’. Specified with upper case or lower case characters.

Value: Specifies user data size with a hexadecimal number.

Data: Byte sequence of user data.

Command option: Specifies the operation of the command and route information.

◇Data transmit command code (Transmission of 6-byte data)

Command string	Hexadecimal code actually sent to the MU-2-R
@DT 06 abc123 CRLF	40,44,54,30,36,61,62,63,31,32,33,0D,0A

Data transmission response basic format

Prefix + command name + ‘=’ + value + terminator

Prefix: ‘*’ = 2Ah, a code that indicates the start of the response string.

Command name: The ASCII characters ‘DT’.

Value: The size of data received with the ‘DT’ command

◇Data transmit response code (255-byte data transmission)

Transmit response character string	Hexadecimal code actually issued from the MU-2-R
*DT=FF CRLF	2A,44,54,3D,46,46,0D,0A

Data receive basic format

Prefix + data receive name + ‘=’ + value 1 + value 2 + data + option data + terminator

Prefix: ‘*’ = 2Ah, a code that indicates the start of the response string.

Data receive name: The 2 ASCII characters ‘DR’, ‘DC’ or ‘DS’.

Value 1: 1 byte hexadecimal value to show the RSSI information. Specified by 2 ASCII characters.

Value 2: 1 byte hexadecimal value to show the size of the user data. Specified by 2 ASCII characters.

Data: Byte sequence of user data.

Option data: Route information and the like.

◇Data receiver code

Data receive (receiving data) character string	Hexadecimal code actually returned from the MU-2-R
*DR=06 abc123 CRLF	2A,44,52,3D,30,36,61,62,63,31,32,33,0D,0A

■ **4.4.1.1 @DT../ data transmit command 1**

The data transmit command 1 '@DT' is a command used for the system not using the relay function. Data is transmitted towards the target station set as the Destination ID at the source station.

1. When the relay function is not used

When the source station MU-2-R receives the command from the user controller, it returns a command response as an acknowledgment of command receipt. At the same time, it starts wireless data transmission. The target station MU-2-R outputs the data receive 1 in the '*DR' format.

Format: '@' + 'DT' + data size + data + 'CRLF'

- Data size is specified by 2 hexadecimal ASCII characters. The maximum data size that can be sent at one time is 255 bytes.
- The data is a numerical value up to 00h to FFh.
- The data is sent to the target station set in the Destination ID: '@DI'.

Format '@DT' ssDD...D 'CRLF'

ss: Shows the data size in 2 hexadecimal digits Value: 00h to FFh

DD...D: D expresses 1-byte data. Value: 00h to FFh, amount of data: maximum 255 bytes

Example: Transmit the 10 bytes of data (0Ah) '0123ABC%#\$' to the target station set in the Destination ID. The target station Equipment ID = 01h. The source station Equipment ID = 5Fh.

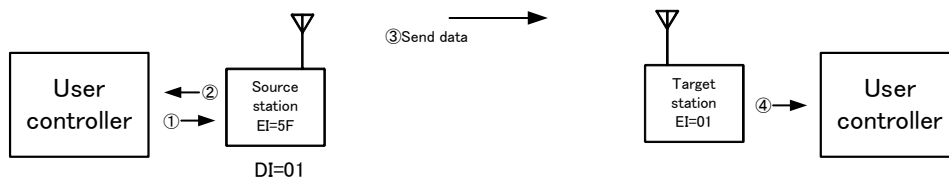

•Source station 5F status

① Issue the data transmit command 1

@DT 0A 0123ABC%#\$ CRLF

② Data transmit response

* DT = 0A CRLF

③ Send data

•Target station 01 status

④ Data receive 1

When RI=OF * DR = 0A 0123ABC%#\$ CRLF(Default)

When RI=ON * DR = 0A 0123ABC%#\$ CRLF

◇ **Data receive 1 (Target station output)**

Example: Receives 5-byte user data (05h) 'ABCDE'

Source station = 01, relay stations = 02, when the received signal level is -69 dBm (45h)

Data transmit command 1 :

@DT 05 ABCDE CRLF

When SI is OF

* DR=05 ABCD CRLF (default)

When SI is ON

* DS=45 05 ABCDE CRLF

*SI = Attach RSSI information mode

■ **4.4.1.2 '@DT.../' Data transmit command 2**

The data transmit command 2 '@DT.../' is a command for the system using relay stations. The data transmit command 2 is provided to handle the user system data mainly.

- The format of this command assumes the relay function, but can also be used for the system not using the relay function. With 1:1 communication, set only one Equipment ID for the target station at the end of the route information.
- If the attach RF received signal level mode setting command '@SI' is used, received signal level information for the packet is attached to the front of the data receive of the target station in response to the data transmit command 2.
- There is also a method of notation where the data transmit command 2 makes the target station return data receive acknowledgement 'ACK'.

1. Receive confirmation acknowledgement: no request for ACK

When the source station MU-2-R receives the data transmit command 2 '@DT.../' from the user controller, it returns a command response as an acknowledgment of command receipt. At the same time, it starts wireless data transmission. The target station MU-2-R outputs the data receive 2 in the '*DR' format. This command does not request the target station to return a data receive acknowledgement 'ACK'.

Format 1: '@' + 'DT' + data size + data + '/R' + route information + 'CRLF'

Format 2: '@' + 'DT' + data size + data + '/R' + 'CRLF'

Details

Format '@DT' ssDD...D '/R' rr,rr,...,rr 'CRLF'

ss: Shows the data size in 2 hexadecimal digits and ASCII characters Value: 00h to FFh, maximum 255 bytes

DD...D: D expresses 1-byte data. Value: 00h to FFh, amount of data: maximum 255 bytes

rr,rr,...,rr: Shows the route information in 2 hexadecimal digits and ASCII characters Value: 00h to FEh, number of relay stations maximum 10 units

- With Format 1, the route information is entered directly in the command.
- With Format 2, transmission is based on route information set in the route register with the RT command or on the content of the Destination ID. When entering the route information, enter the Equipment ID of the target unit at the end. If no route information is set (NA set for the RT command), the equipment set as the Destination ID will be the target station.
- To output the same data from all currently connected relay stations, issue the command with '/S' instead of '/R'.

Example: Transmit the 10-byte (0Ah) data '0123ABC\$#4' to target station ID = 8F via relay station IDs = 01, 02, 03. The source station Equipment ID = 5F.

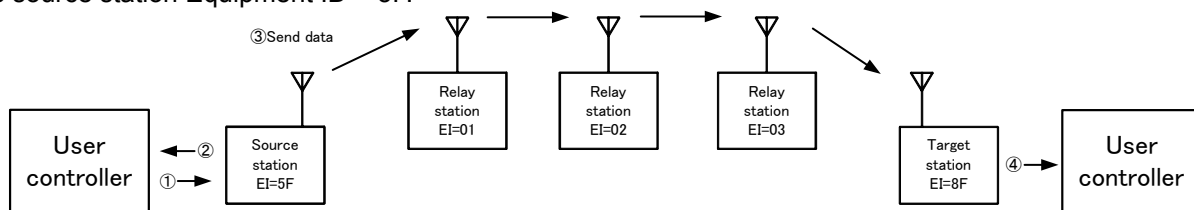

•Source station 5F status

①Issue the data transmit command 2

Format 1:@DT 0A 0123ABC\$#4 /R 01.02.03.8F CRLF

Format 2:@DT 0A 0123ABC\$#4 /R CRLF

②Data transmit response

*DT=0A CRLF

③Send data

•Target station 8F status

④Data receive 2

When RI=OF *DR=0A 0123ABC\$#4 CRLF(Default)

When RI=ON *DR=0A 0123ABC\$#4 /R 5F.01.02.03 CRLF

* The relay stations output the same data as from the target station with '/S' .

◇ Data receive 2

Example: Receives 5-byte user data (05h) 'ABCDE'

Source station = 01, relay stations = 02, target station=03, when the received signal level is -69 dBm (45h)

Data transmit command 2 without ACK : @DT 05 ABCDE /R 02,03 CrLf

When RI=OFF (default)

When SI=OFF

When SI= ON

When RI=ON

When SI=OFF

When SI= ON

*DR=05 ABCD CrLf(default)

*DS=45 05 ABCDE CrLf

*DR=05 ABCD /R 01,02 CrLf

*DS=45 05 ABCDE /R 01,02 CrLf

* RI = Attach route information mode, SI = Attach RSSI information mode

2. Receive confirmation acknowledgement: with request for ACK

When the source station MU-2-R receives the data transmit command 2 '@DT.../A' from the user controller, it returns a response as an acknowledgment of command receipt. At the same time, it starts wireless data transmission. The target station MU-2-R outputs the data receive 2 in the '*DR' format. This command requests the target station to return a data receive acknowledgment 'ACK'.

Format 1: '@' + 'DT' + data size + data + '/A' + route information + 'CrLf'

Format 2: '@' + 'DT' + data size + data + '/A' + 'CrLf'

Details

Format '@DT' ssDD...D '/A' rr,rr,...,rr 'CrLf'

ss: Shows the data size in 2 hexadecimal digits and ASCII characters Value: 00h to FFh, maximum 255 bytes

DD...D: D expresses 1-byte data. Value: 00h to FFh, amount of data: maximum 255 bytes

rr,rr,...,rr: Shows the route information in 2 hexadecimal digits and ASCII characters Value: 00h to FEh, number of relay stations maximum 10 units

- With Format 1, the route information is entered directly in the command.
- With Format 2, transmission is based on route information set in the route register with the RT command or on the content of the Destination ID. When entering the route information, enter the Equipment ID of the target unit at the end. If no route information is set (NA set for the RT command), the equipment set as the Destination ID will be the target station.
- To output the same data from all currently connected relay stations, issue the command with '/B' instead of '/A'.

Example: Transmit the 10-byte (0Ah) data '0123ABC%#4' to target station ID = 8F via relay station IDs = 01, 02, 03, and get ACK from the target station. The source station Equipment ID = 5F.

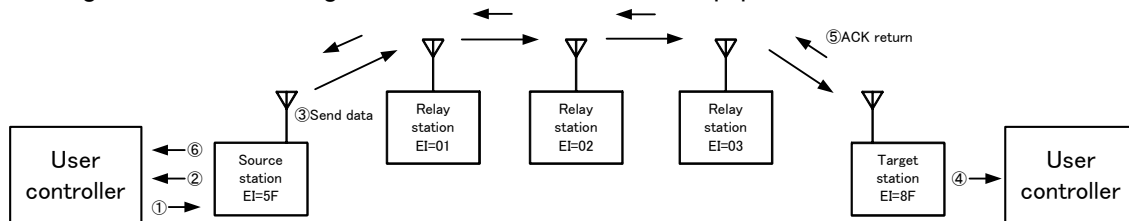

• Source station 5F status

- ① Issue the data transmit command 2
Format 1: @DT 0A 0123ABC\$#4 /A 01.02.03.8F CrLf
Format 2: @DT 0A 0123ABC\$#4 /A CrLf
- ② Data transmit response
*DT=0A CrLf
- ③ Send data
- ⑥ ACK response
*DR=00 CrLf (issued after the relay time has elapsed)

• Target station 8F status

- ④ Data receive 2
When RI=OF *DR=0A 0123ABC\$#4 CrLf(Default)
When RI=ON *DR=0A 0123ABC\$#4 /A 5F.01.02.03 CrLf
- ⑤ ACK return

The relay stations outputs the same data as from the target station with '/S'.

◇ **Data receive 2 (Target station output)**

Example: Receives 5-byte user data (05h) 'ABCDE'

Source station = 01, relay station = 02, target station=03, when the received signal level is -69 dBm (45h)

Data transmit command 2 with ACK : @DT 05 ABCDE /A 02,03 CrLf

When RI=OFF (default)

When SI=OFF

*DR=05 ABCD CrLf(default)

When SI= ON

*DS=45 05 ABCDE CrLf

When RI=ON

When SI=OFF

*DR=05 ABCD /A 01,02 CrLf

When SI= ON

*DS=45 05 ABCDE /A 01,02 CrLf

* RI = Attach route information mode, SI = Attach RSSI information mode

◇ **ACK response (Source station output)**

When the data transmit command 2 with ACK is issued from the source station, an ACK response is output from the source station. If the attach RF received signal level mode setting command '@SI' is set to ON, RSSI information for the ACK signal from the target station is attached to the ACK response. The ACK response is issued after the relay time has elapsed.

Example: The appearance of the source station ACK response when the 10-byte (0Ah) data 'PPPPPPPPPP' is transmitted with the data transmit command 2 with ACK.

Source station equipment ID = 01, relay station equipment ID = 02, target station equipment ID = 03

When the received signal level of the ACK signal is -102 dBm (66h)

1. When the mode setting with RF received signal level information SI is OF

Following the characters '*DR', '00' indicating the ACK response are output.

Issue data transmit command 2 with ACK

@DT 0A PPPPPPPPPP /A 02,03 CrLf

• Source station output

*DT=0A CrLf

← Data transmit response

*DR=00 CrLf

← ACK response (issued after the relay time has elapsed)

• Target station output

*DR=0A PPPPPPPPPP CrLf

← Data receive 2, RI=OF

2. When the mode setting with RF received signal level information SI is ON

Following the characters '*DS', the RSSI information and '00' indicating the ACK response are output.

Issue data transmit command 2 with ACK

@DT 0A PPPPPPPPPP /A 02,03 CrLf

• Source station output

*DT=0A CrLf

← Data transmit response

*DS=66 00 CrLf

← ACK response (issued after the relay time has elapsed)

• Target station output

*DR=0A PPPPPPPPPP /A 01,02 CrLf

←Data receive 2, RI=ON

■ **4.4.1.3 @DT...% Data transmit command 3**

The data transmit command 3 '@DT...%' is a command for the system using relay stations. When transmitting the user system data using the data transmit command 2, it may be also required to perform various controls at the same time. In this case, using the data transmit command 3 for control purpose makes it easy to design the program.

- The format of this command assumes the relay function, but can also be used for the system not using the relay function. With 1:1 communication, set only one Equipment ID for the target station at the end of the route information.
- Received signal level information for the packet is always included at the front of the data receive of the target station in response to the data transmit command 3.
- There is also a method of notation where the data transmit command 3 makes the target station return data receive acknowledgement 'ACK'.

1. Receive confirmation acknowledgement: no request for ACK

When the source station MU-2-R receives the data transmit command 3 '@DT...%' from the user controller, it returns a response as an acknowledgment of command receipt. At the same time, it starts wireless data transmission. The target station MU-2-R outputs the data receive 3 in the '*DC' format. This command does not request the target station to return a data receive acknowledgement 'ACK'.

Format 1: '@' + 'DT' + control size + control + '%R' + route information + + 'CRLF'

Format 2: '@' + 'DT' + control size + control + '%R' + 'CRLF'

Details

Format '@DT' ssDD...D '%R' rr,rr,...,rr 'CRLF'

ss: Shows the control size in 2 hexadecimal digits and ASCII characters Value: 00h to FFh, maximum 255 bytes

DD...D: D expresses 1-byte data. Value: 00h to FFh, amount of data: maximum 255 bytes

rr,rr,...,rr: Shows the route information in 2 hexadecimal digits and ASCII characters Value: 00h to FEh, number of relay stations maximum 10 units

- With Format 1, the route information is entered directly in the command.
- With Format 2, transmission is based on route information set in the route register with the RT command. When entering the route information, enter the Equipment ID of the target unit at the end. With 1:1 communication, set only one Equipment ID for the target station in the route information. If no route information is set (NA set for the RT command), the equipment set as the Destination ID will be the target station.
- To output the same control from all currently connected relay stations, issue the command with '%S' instead of '%R'.

Example: Transmit the 10-byte (0Ah) control '0123ABC\$#4' to target station ID = 8F via relay station IDs = 01, 02, 03. The source station Equipment ID = 5F.

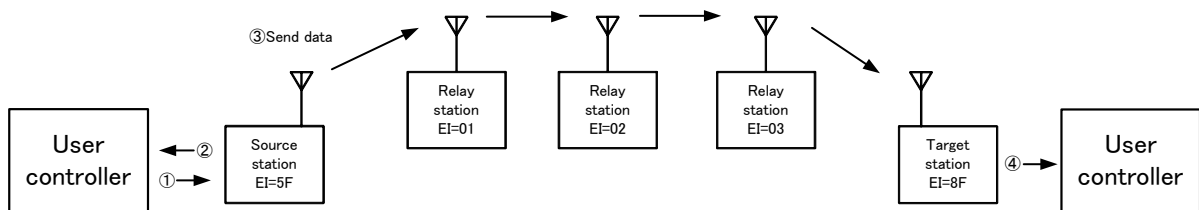

• Source station 5F status

- ① Issue the data transmit command 3
Format 1: @DT 0A 0123ABC\$#4 %R 01.02.03.8F CRLF
Format 2: @DT 0A 0123ABC\$#4 %R CRLF
- ② Data transmit response
*DT=0A CRLF
- ③ Send data

• Target station 8F status

- ④ Data receive 3
When RI=OF *DC=45 0A 0123ABC\$#4 CRLF(Default)
When RI=ON *DC=45 0A 0123ABC\$#4 /R 5F.01.02.03 CRLF

* '45h' at the front indicates the signal level of the received packet. In this case, it is -69 dBm (45h).

For details of the value, refer to the 'RA' command.

* When RI = ON, the delimiter character is '/', not '%'.

◇Data receive 3

Example: Receives 5-byte user data (05h) 'ABCDE'

Source station = 01, relay station = 02, when the received signal level is -69 dBm (45h)

Data transmit command 3 without ACK : `@DT 05 ABCDE %R 02,03 CRLF`

When RI is OF *`DC=45 05 ABCD CRLF` (default)

When RI is ON *`DC=45 05 ABCDE /R 01,02 CRLF*1`

*01= Note that the '%' for data transmit commands is '/' for data receives.

2. Receive confirmation acknowledgement: with ACK

When the source station MU-2-R receives the data transmit command 3 '@DT...%' from the user controller, it returns a response as an acknowledgment of command receipt. At the same time, it starts wireless data transmission. The target station MU-2-R outputs the data receive 3 in the '*DC' format. This command requests the target station return data receive acknowledgment 'ACK'.

Format 1: '@' + 'DT' + control size + control + '%A' + route information + 'CRLF'

Format 2: '@' + 'DT' + control size + control + '%A' + 'CRLF'

Details

Format '@DT' ssDD...D '%A' rr,rr,...,rr 'CRLF'

ss: Shows the control size in 2 hexadecimal digits and ASCII characters Value: 00h to FFh, maximum 255 bytes

DD...D: D expresses 1-byte data. Value: 00h to FFh, amount of data: maximum 255 bytes

rr,rr,...,rr: Shows the route information in 2 hexadecimal digits and ASCII characters Value: 00h to FEh, number of relay stations maximum 10 units

- With Format 1, the route information is entered directly in the command.
- With Format 2, transmission is based on route information set in the route register with the RT command. When entering the route information, enter the Equipment ID of the target unit at the end. With 1:1 communication, set only one Equipment ID for the target station in the route information. If no route information is set (NA set for the RT command), the equipment set as the Destination ID will be the target station.
- To output the same data from all currently connected relay stations, issue the command with '%B' instead of '%A'.

Example: Transmit the 10-byte (0Ah) control '0123ABC\$#4' to target station ID = 8F via relay stations ID = 01, 02, 03. The source station Equipment ID = 5F.

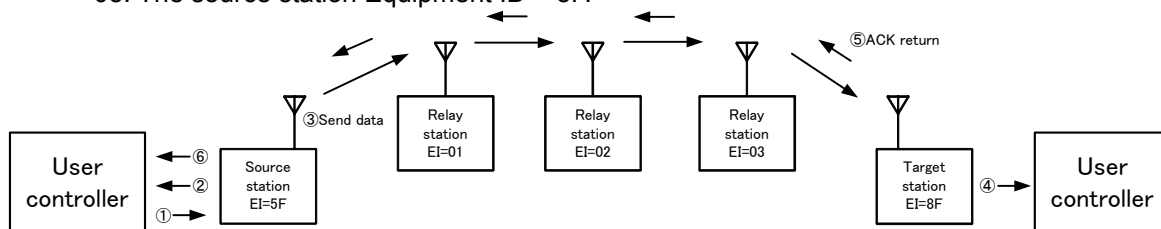

•Source station 5F status

- ① Issue the data transmit command 3
Format 1: `@DT 0A 0123ABC$#4 %A 01,02,03,8F CRLF`
Format 2: `@DT 0A 0123ABC$#4 %A CRLF`
- ② Data transmit response
*`DT=0A CRLF`
- ③ Send data
- ⑥ ACK response
*`DC=45 00 CRLF` (issued after the relay time has elapsed)

•Target station 8F status

- ④ Data receive 3
When RI=OF *`DC=45 0A 0123ABC$#4 CRLF`(Default)
When RI=ON *`DC=45 0A 0123ABC$#4 /A 5F,01,02,03 CRLF`
- ⑤ ACK return

*'45h' at the front indicates the signal level of the received packet. In this case, it is -69 dBm (45h).

For details of the value, refer to the 'RA' command.

*When RI = ON, the delimiter character is '/', not '%'.

◇ **Data receive 3 (Target station output)**

Example: Receives 5-byte user data (05h) 'ABCDE'

Source station = 01, relay station = 02, when the received signal level is -69 dBm (45h)

Data transmit command 3 with ACK :	<u>@DT 05 ABCDE %A 02,03</u> CRLF
When RI is OF	* <u>DC=45 05 ABCD</u> CRLF (default)
When RI is ON	* <u>DC=45 05 ABCDE /A 01,02</u> CRLF *1

*01= Note that the '%' for data transmit commands is '/' for data receives.

◇ **ACK response (Source station output)**

When the data transmit command 3 with ACK is issued from the source station, an ACK response is output from the source station. Regardless of the mode set with the attach RF received signal level mode setting command '@SI', RSSI information for the received signal at the target station is attached to the ACK response. The ACK response is issued after the relay time has elapsed.

Example: The appearance of the source station ACK response when the 10-byte (0AH) data 'PPPPPPPPPP' is transmitted with the control transmit command 3 with ACK.

Following the characters 'DC', the RSSI information and '00' indicating the ACK response are output.

Source station equipment ID = 01, relay station equipment IDs = 02, 03, target station equipment ID = 04

When the received signal level of the target station is -85 dBm (55h)

Issue Data transmit command 3 with ACK	<u>@DT 0A PPPPPPPPPP %A 02,03,04</u> CRLF
• Source station output	
* <u>DT=0A</u> CRLF	← Data transmit response
* <u>DC=55 00</u> CRLF	← ACK response (issued after the relay time has elapsed)
• Target station output	
* <u>DC=55 0A PPPPPPPPPP</u> CRLF (default)	← Data receive 3, RI=OF
* <u>DC=55 0A PPPPPPPPPP /A 01,02,03</u> CRLF	← Data receive 3, RI=ON

■ **4.4.2.3 @DI Destination ID setting**

Sets the destination (target station). Refer also to the explanation of User ID and Group ID.
 If 00 is specified as the Destination ID, all equipment within the same group will receive the data at the same time (broadcast function). If FFh is set, the data is sent but no station will receive it.
 The broadcast function can not be used when using the relay function.

Default: 01h
 Value: 00h to FFh (00h and FFh are special operations)

Example: Change the Destination ID to 25h
 Control command: **@DI 25**CRLF Control response: ***DI=25**CRLF

■ **4.2.2.4 @EC Error correction protocol setting**

Specifies whether or not to set the communication protocol to the error correction protocol.
 In order to set to the error correction protocol, set to ON, I1 or I2. This command requires the command option '/W'.
 If the '@EC' command is issued, the internal settings of the MU-2-R are initialized. A communication protocol used when the error correction protocol is off is defined as the standard protocol.

Default: OF Error correction protocol OFF (=standard protocol)
 Value: OF = Error correction protocol OFF (=standard protocol)
 ON = Error correction protocol without interleave
 I1 = Error correction protocol with interleave 1
 I2 = Error correction protocol with interleave 2

Example 1 Set to the error correction protocol
 Control command: **@EC ON /W**CRLF
 Control response: ***WR=PS**CRLF ***EC=ON**CRLF

Example 2 Terminate the error correction protocol (set to the standard protocol)
 Control command: **@EC OF /W**CRLF
 Control response: ***WR=PS**CRLF ***EC=OF**CRLF

Communication availability

Communication protocol for transmission			Communication protocol for receiving (○:Communication can be established)			
	Data size	Applicable command	Standard protocol @EC OF/W	Error correction protocol Without interleave @EC ON/W	Error correction protocol Interleave 1 @EC I1/W	Error correction protocol Interleave 2 @EC I2/W
Standard protocol @EC OF/W	0~255	All	○	×	×	×
Error correction protocol Without interleave @EC ON/W	0~255	All	×	○	○	○
Error correction protocol Interleave 1 @EC I1/W	0~8	@DT @CP	×	×	○	×
Error correction protocol Interleave 2 @EC I2/W	0~32	@DT @CP	×	×	×	○

■ 4.4.2.5 @EI Equipment ID setting

Sets the Equipment ID. One group can contain 254 units. Refer also to the explanation of User ID and Group ID. The Equipment ID 00h is used for the broadcast function, and there is no reason for setting it. If the Equipment ID FFh is specified, data will not be received. In this case, if the '@RA' command is used, only RSSI level data is output.

Default: 01h

Value: 01h to FFh (FFh is a special operation)

Example: Change the Equipment ID to 34h

Control command: @EI 34_{CrLf}

Control response: *EI=34_{CrLf}

■ 4.4.2.6 @GI Group ID setting

Sets the Group ID. Refer also to the explanation of the User ID.

There are 256 Group IDs. Maintain these IDs for use as identification numbers when building other user systems.

Default: 00h

Value: 00h – FFh

Example: Change the Group ID to 34h

Control command: @GI 34_{CrLf}

Control response: *GI=34_{CrLf}

■ 4.4.2.7 @IZ Initialize

Returns the MU-2-R to the factory default values. The content of the EEPROM fixed with the 'W' option is also initialized. For default values, refer to each command.

After using this command, always execute the SR command.

Example:

Control command: @IZ_{CrLf}

Control response from the MU-2-R:

When RM = CD *IZ=00_{CrLf}

When RM = TX *IZ=00: ROM was initialized. _{CrLf}

■ 4.4.2.8 @MD Operation mode register setting

Sets the MU-2-R operation mode register. The mode is determined in accordance with the status of the MODE terminal. For details, refer to the item "Modes". No commands can be used except in the command mode (CD).

Default: CD

Value: CD: Command mode TX: Text mode BI: Binary mode

Example 1: Change to the text mode

Control command: @MD TX_{CrLf}

Control response: *MD=TX_{CrLf}

Example 2: Change to the binary mode

Control command: @MD BI_{CrLf}

Control response: *MD=BI_{CrLf}

■ 4.4.2.9 @PB UART parity bit setting

Sets the UART parity bit of the MU-2-R. The change of setting is applied immediately after the response to the command is returned. Change the parity on the control side immediately.

Default: NO

Value: NO = None EV = Even OD = Odd

Example: Change to even parity

Control command: @PB EV_{CrLf}

Control response: *PB=EV_{CrLf}

■ 4.4.2.10 @PW Antenna power setting

Lowers the antenna power of the MU-2-R from the standard 10 mW to 1 mW.

Default: 10 (10 mW)
Value: 01 = 1 mW 10 = 10 mW

Example Set to 1 mW

Control command: @PW01CRLF Control response: *PW=01CRLF

■ 4.4.2.11 @RM Response display mode

Sets the method of displaying the content of responses to either code or text.

Text display is the mode for connecting to a PC with an RS232C conversion board in order to check the content of responses.

Normally the code display mode should be used.

Default: CD

Value: CD: Code display mode TX: Code and text display mode

Example: Change the response display method to code display

Control command: @RMCDCRLF Control response: : *RM=CDCRLF

■ 4.4.2.12 @RT Relay route designation

Sets the route information in the route register. Setting is possible up to a maximum of 10 relay stations. When entering the route information, enter the Equipment IDs (EI) of the relay stations in the order of the relay. Specify the Equipment ID (EI) of the target station at the end. For details of data transmission using relay stations, refer to the DT command.

Default: NA A response corresponding to the @RT command is **RT=NA

Value: NA or (00h – FEh),.....,(00h-FE) A maximum number of 10 units can be specified

However, 00h is for the broadcast communication and setting NA disables the route information in the route register and enables the ID set with the @DI command.

Example: Set route information for transmitting 'ABC' from the source station with Equipment ID = 5F via relay station IDs 01, 02 and 03 to target station Equipment ID = 8F.

Control command: @RT01.02.03.8FCRLF

Control response: *RT=01.02.03.8FCRLF

Hint: When only one Equipment ID is entered in the RT command, that becomes the direct target station.

■ 4.4.2.13 @SB UART stop bit setting

Sets the UART stop bit of the MU-2-R. The change of setting is applied immediately after the response to the command is returned. Change the stop bit on the control side immediately.

Default: 01

Value: 01 = Stop bit 1 02 = Stop bit 2

Example: Change to Stop bit 1

Control command: @SB01CRLF Control response: *SB=01CRLF

■ **4.4.2.14 @SI Mode setting with RF received signal level information**

Sets whether or not to include the RF received signal level information (RSSI) of the received packet data in the data receive at the source station or the ACK response and receive response at the source station. To include the information, set the mode to ON. The information is attached to the front of the data receive (“*DS’). With OF, the data receive is “*DR’. This mode is applied to all commands which involve receiving operation at the source station or target station. However with the data transmit command 3, RSSI information is always added to the data receive character string or AKC response character string.

Default: OF
 Value ON: Attach RSSI information OF: No RSSI information

Example 1: Attach RSSI information mode setting

Control command: @ SI ONCrLf Control response: * SI=ONCrLf

Example 2: Appearance of the target station data receive and source station ACK response

Target station data receive

when the RSSI of the received packet data is -85 dBm = 55 hex

- When the data transmit command 2 is issued from the source station

When SI = ON, RI = OF	* <u>DS=55 03 ABC</u> CrLf
When SI = ON, RI = ON	* <u>DS=55 03 ABC /R20,01,02,03</u> CrLf
When SI = OF, RI = OF	* <u>DR=03 ABCC</u> CrLf
When SI = OF, RI = ON	* <u>DR=03 ABC /R20,01,02,03</u> CrLf

Source station ACK response

when the RSSI of the ACK response received from the target station is -70 dBm=46 hex

- When the data transmit command 2 is issued from the source station

When SI = OF	* <u>DR=00</u> CrLf
When SI = ON	* <u>DS=46 00</u> CrLf

■ **4.4.2.15 @SR Reset**

Returns the MU-2-R to the status when the power is turned on. The MU-2-R starts up with the fixed content of the EEPROM with the ‘/W’ option. The command response for the ‘SR’ command is issued immediately after the command is received. The time for commands not to be received is 120 ms when the ‘@SR’ command is issued and 100 ms when the hardware is reset at the INI terminal.

Example:

Control command: @ SRCrLf
 Control response:
 When RM = CD * SR=00CrLf
 (When RM = TX * SR=00: Software reset was performed. CrLf)

■ **4.4.2.16 @TB Time without input in the binary mode setting**

In the binary mode, if the status where no UART data is input continues beyond the set time, transmission of data in the buffer starts automatically.
 Calculate the setting value with 32 ms per 1 count.

Default: 10h (16 × 32 = 0.512 s)
 Value: 01h to FFh: 1 count = 32 ms

Example: Set the time to 20h (1.02 s)

Control command: @ TB 20CrLf Control response: * TB=20CrLf

■ 4.4.2.17 @UI User ID setting

User IDs are IDs (about 30,000) that are meant to prevent data interference with other systems within a given area, and if all the equipment within the same user system does not have the same ID, communication cannot be established. The link parameters derive from the Group ID, Equipment ID, and Destination ID.

All MU-2-R units have a default User ID of 0000h, and they can be used with this value, but to avoid data collision with other users in the same area, we recommend that you set a User ID other than 0000h for actual operations with the MU-2-R.

If a unique User ID is required, we will provide it along with a password. Please contact Circuit Design, Inc directly. Please ensure that you do not lose your User ID and password (We also manage them).

*About 30,000 User IDs are ensured, but there may be duplicates if the IDs should be required in excess of this range. In other words, the User ID does not guarantee the security of data. However since it is not likely that more than 30,000 User IDs are issued and there is also a very small possibility of overlapping in the same area, you can use it at ease.

A password is required for setting a User ID, but the passwords for the following 16 User IDs are publicly available so they can be used freely. The password follows the User ID in brackets.

**0000(0B27),EFF1(4E74),EFF2(D18E),EFF3(5909),EFF4(82B5),
EFF5(9D47),EFF6(E4D1),EFF7(3B2F),EFF8(B3A6),EFF9(6C5A),
EFFA(C6F7),EFFB(7F6F),EFFC(15C4),EFFD(0A34),EFFE(F7E8),EFFF(A09C)**

Default: 0000h

Value: 01h to FFh (0000h is for testing, FFh cannot be used)

Example: Set the User ID to 0000h with the password 0B27h provided.

Control command: **@UI 0000,0B27**_{CrLf} Control response: *** * UI=0000**_{CrLf}

* For ordinary applications, fix the UI, GI, and EI in the EEPROM with the command /W option.

*Please contact the distributor or Circuit Design, Inc. if you require multiple User IDs.

■ 4.4.3 Monitor commands and Responses

■ 4.4.3.1 @CR Target station RSSI absolute level measurement

Measures the RSSI (Received Signal Strength Intensity) of the specified target station. The RSSI value is the received signal strength of the target station. In addition, the floor noise level of the field where the target station is located can also be acquired. The measured value is output as a 2-digit hexadecimal number in ASCII characters that expresses the absolute value for RSSI. The code of the RSSI value acquired is minus.

Format 1: '@' + 'CR' + '/' + route information + CrLf
 Format 2: '@' + 'CR' + CrLf

Details

Format1: '@CR/'rr,rr,...,rr 'CrLf'

Format2: '@CR/CrLf'

rr,rr,...,rr: Shows the route information in 2 hexadecimal digits and ASCII characters Value: 00h to FEh, number of relay stations maximum 10 units

- With Format 1, the route information is entered directly in the command.
- With Format 2, transmission is based on route information set in the route register with the RT command or on the content of the Destination ID. When entering the route information, enter the Equipment ID of the target unit at the end. If no route information is set (NA set for the RT command), the equipment set as the Destination ID will be the target station.
- It is possible to make the source unit the target. In this case, after entering one or more relay stations, enter the Equipment ID of the source unit at the end.

Example: Measure the RSSI of target equipment number 8F. The relay stations are 01, 02, and 03.

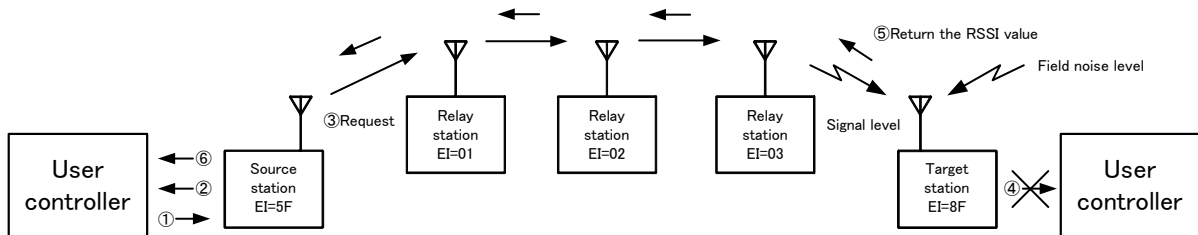

• Source station 5F status

- ① Issue the monitor command
 Format 1: @CR / 01.02.03.8F CrLf
 Format 2: @CR CrLf
- ② Monitor response: *CR=00 CrLf
- ③ Request
- ⑥ Receive response from the target station (issued after the relay time has elapsed)
 When RM=CD *DR=04 5580 CrLf
 When RM=TX *DR=14 CrLf S -85dBm N -128dBm CrLf

• Target station 8F status

- ④ There is no data receive
- ⑤ Return the RSSI value of the current channel
 Measure and return the packet signal level and field noise.

◇ Receive response (Source station output)

The signal level and filed noise level of the target station are output as the receive response. The measured value is output following the data size as a 2-digit hexadecimal number that expresses the absolute value for RSSI. The RSSI value for one channel is expressed as 2-byte ASCII characters and the code of the RSSI value acquired is minus.

- Source station output
- *DR=04 55 80 CrLf
- * Hex '55'=-85 dBm, Hex '80'=-128 dBm, '55'=35,35 (ASCII code)

■ **4.4.3.2 @RA RSSI absolute value measurement**

Measures the absolute value for Received Signal Strength Intensity (RSSI) of the channel set. The measured value is a hexadecimal value that indicates the RSSI absolute value. The code of the RSSI value acquired is minus.

Format 1: '@' + 'RA' + 'CRLF'

Details

Format: '@RACRLF'

Range of the hexadecimal value that indicates the RSSI absolute value: 00h to FFh

Example: Measure the RSSI absolute value of the current channel

Monitor command: @RACRLF

Monitor response:

When RM = CD *RACRLF *63h = 99

(When RM = TX *RA=63 -99dBmCRLF)

■ **4.4.4 Test commands and Responses**

■ **4.4.4.1 @CT Test data transmission**

Transmits test data from the source station for the time specified. Specify 'ON' to transmit data continuously, specify a count value when transmitting for a specified time, and specify 'OF' to stop transmission. The transmission data is the 'CRLF' sent repeatedly, and the receive response of the target station is '*DR=00'. If there is any input data during transmission, the data is transmitted.

Default: 'OF'

Value: 'ON': Continuous transmission (on), 'OF': Continuous transmission (off), Count value: ASCII code that expresses 01h to FFh

The count value is 10 seconds per count. The maximum value is FFh, 2,550 seconds.

Example 1: Continuous data transmission on

Test command: @CT ONCRLF

Test response: *CT=ONCRLF

Example 2: Continuous data transmission off

Test command: @CT OFCRLF

Test response: *CT=OFCRLF

Example 3: Transmit data for 60 seconds

Test command: @CT 06CRLF

Test response: *CT=ONCRLF

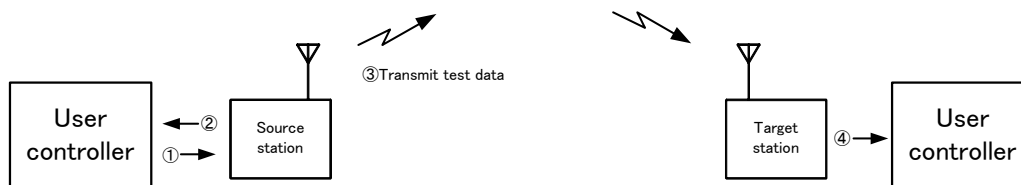

• Source station 5F status

- ① Issue the test command @CT 06 CRLF
- ② Test response: *CT=ON CRLF
- ③ Transmit test data

• Status of all target stations

- ④ Data receive *DR=00
- If the Destination ID matches, data receive is output for specified time.
- To measure the RSSI of the test signal, set the target station Equipment ID to 'FFh' and use the '@RA' command.

■ **4.4.4.2 @CP Packet test**

Transmits data for packet testing.

Transmits data packets to the specified target unit, and the target unit returns the data without change. Any packet length of 1 to 255 bytes can be specified.

Format 1: '@' + 'CP' + data size + data + '/' + route information + 'CRLF'

Format 2: '@' + 'CP' + data size + data + 'CRLF'

Details

Format1: '@CP'ssDD...D '/A' rr,rr,...,rr 'CRLF'

Format2: '@CP'ssDD...D '/ACRLF'

ss: Shows the data size in 2 hexadecimal digits and ASCII characters Value: 00h to FFh, maximum 255 bytes

DD...D: D expresses 1-byte data. Value: 00h to FFh, amount of data: maximum 255 bytes

rr,rr,...,rr: Shows the route information in 2 hexadecimal digits and ASCII characters Value: 00h to FEh, number of relay stations maximum 10 units

- With Format 1, the route information is entered directly in the command.
- With Format 2, transmission is based on route information set in the route register with the RT command or on the content of the Destination ID. When entering the route information, enter the Equipment ID of the target unit at the end. If no route information is set (NA set for the RT command), the equipment set as the Destination ID will be the target station.

Example: Transmit 'ABC' from the source station with Equipment ID = 5F via relay station IDs 01, 02 and 03 to target station Equipment ID = 8F, and the data is returned without change.

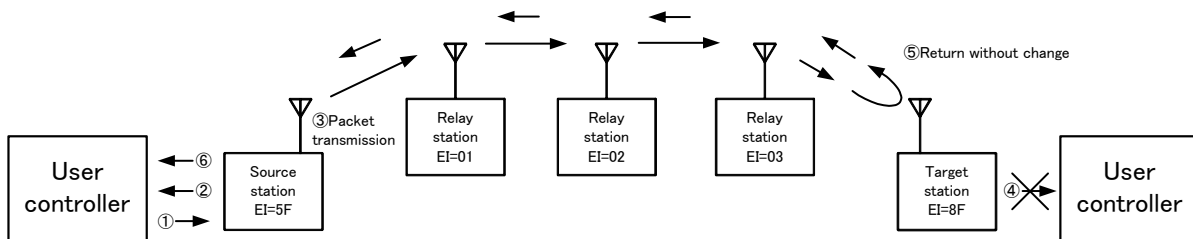

• Source station 5F status

- ① Issue the test command
Format 1: @CP 03 ABC / 01.02.03.8F CRLF
Format 2: @CP 03 ABC CRLF
- ② Test response: *CP=00 CRLF
- ③ Transmit data packet
- ⑥ Receive response from the target station
*DR=03 ABC CRLF (issued after the relay time has elapsed)

• Target station 8F status

- ④ There is no data receive
- ⑤ Return the data packet without change

◇ **Receive response (Source station output)**

The packet data sent to the target station is returned without change and output as the receive response.

• Source station output

*DR=03 ABC CRLF

4.4.5 Extended command and extended response

■ **4.4.5.1 '@DTxx@CHxx/C' Change the target station channel**

Changes the channel used by the specified target station. Start changing the channels of the equipment located furthest away.

- Format 1: '@' + 'DT05@CH' + channel number + '/C' + route information + 'CRLF'
- Format 2: '@' + 'DT05@CH' + channel number + '/C' + 'CRLF'
- Format 3: '@' + 'DT07@CH' + channel number + '/W/C' + route information + 'CRLF'
- Format 4: '@' + 'DT07@CH' + channel number + '/W/C' + 'CRLF'

Details

- Format 1: '@DT05@CH' cc '/C' rr,rr,...,rr 'CRLF'
- Format 2: '@DT05@CH' cc '/CCRLF'
- Format 3: '@DT07@CH' cc '/W/C' rr,rr,...,rr 'CRLF'
- Format 4: '@DT07@CH' cc '/W/CCRLF'

cc: Enter the channel number in 2 hexadecimal digits and ASCII characters Value: 01h to 7Fh
 rr,rr,...,rr: Shows the route information in 2 hexadecimal digits and ASCII characters Value: 00h to FEh, number of relay stations maximum 10 units

- With Format 1,3, the route information is entered directly in the command.
- With Format 2,4, transmission is based on route information set in the route register with the RT command or on the content of the Destination ID. When entering the route information, enter the Equipment ID of the target unit at the end. If no route information is set (NA set for the RT command), the equipment set as the Destination ID will be the target station.
- Formats 3 and 4: To fix the changed channel in the EEPROM, attach the '/W' option.

Example: Change the channel of the target station equipment number = 8F to 14ch (0E) channel. The relay stations are 01, 02, and 03.

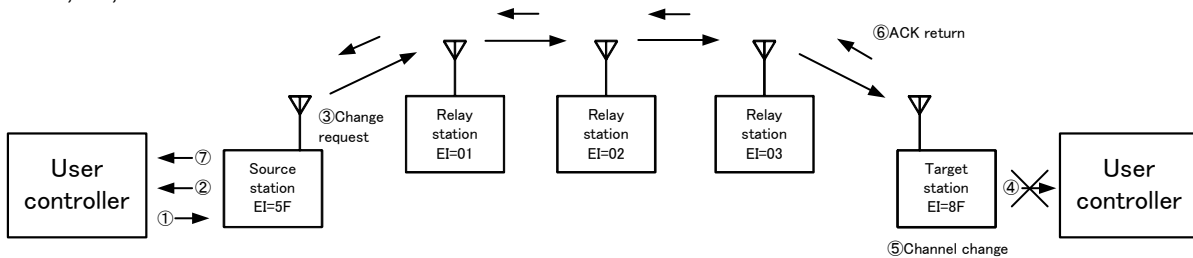

• Source station 5F status

- ① Issue the extended command
 Format 1: @DT 05 @CH0E /C 01.02.03.8F CRLF
 Format 2: @DT 05 @CH0E /C CRLF
- ② Extended response *DI=05 CRLF
- ③ Channel change request
- ⑦ ACK response (issued after the relay time has elapsed)
 *DR=05 @CH0E CRLF

• Target station 8F status

- ④ There is no data receive
- ⑤ Change the channel
- ⑥ ACK return (Channel change completion notice)

◇ **ACK response (Source station output)**

When the channel of the target station is changed, the change result is output as the ACK response.

- Source station ACK response output (Changed to 14 channel)
 *DR=05 @CH0E CRLF

■ 4.4.5.2 '@DTxx@CHxx/F' Changing channels of multiple stations at once

Changes the channels used by multiple specified target stations at once. It is possible to change the channels of the stations and source station entered in the route information at once. The timing by which the channels of the stations are changed is the moment when, after the target stations receive the change channel command from the source station, the ACK responses are received by the various stations. Stations that cannot confirm the ACK signal due to an error remain in their original channel. In this case, investigate the channel range of the system, and change the channels with the target station channel changing command, starting with the most distant stations.

- Format 1: '@' + 'DT05@CH' + channel number + '/F' + route information + 'CRLF'
- Format 2: '@' + 'DT05@CH' + channel number + '/F' + 'CRLF'
- Format 3: '@' + 'DT07@CH' + channel number + '/W/F' + route information + 'CRLF'
- Format 4: '@' + 'DT07@CH' + channel number + '/W/F' + 'CRLF'

Details

- Format 1: '@DT05@CH' cc '/F' rr,rr,...,rr 'CRLF'
- Format 2: '@DT05@CH' cc '/FCRLF'
- Format 3: '@DT07@CH' cc '/W/F' rr,rr,...,rr 'CRLF'
- Format 4: '@DT07@CH' cc '/W/FCRLF'
- cc: Enter the channel number in 2 hexadecimal digits and ASCII characters Value: 01h to 7Fh
- rr,rr,...,rr: Shows the route information in 2 hexadecimal digits and ASCII characters Value: 00h to FEh, number of relay stations maximum 10 units

- With Format 1,3, the route information is entered directly in the command.
- With Format 2,4 transmission is based on route information set in the route register with the RT command or on the content of the Destination ID. When entering the route information, enter the Equipment ID of the target unit at the end. If no route information is set (NA set for the RT command), the equipment set as the Destination ID will be the target station.
- Formats 3 and 4: To fix the changed channel in the EEPROM, attach the '/W' option.

Example: Change the channel of the target station equipment number = 8F to 14ch (0E) channel. The relay stations are 01, 02, and 03.

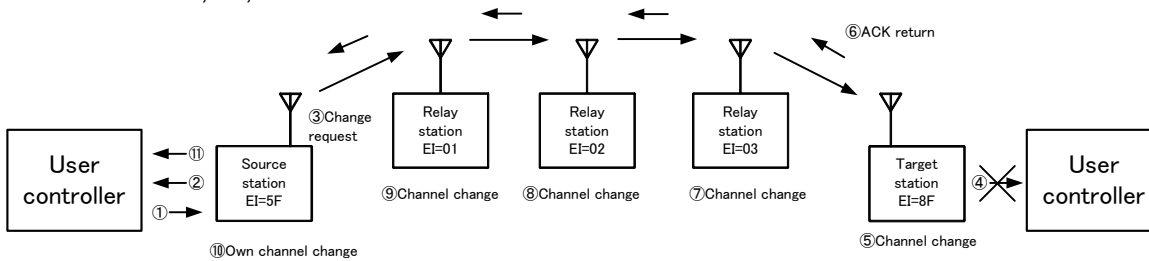

• Source station 5F status

- ① Issue the extended command
Format 1: @DT 05 @CH0E /F 01.02.03.8F CRLF
Format 2: @DT 05 @CH0E /F CRLF
- ② Extended response *DT=05 CRLF
- ③ Channel change request
- ⑩ Change the own channel
- ⑪ Control response
*CH=0E CRLF
(Output when the target station channel is changed)

• Target station 8F status

- ④ There is no data receive
- ⑤ Change the channel
- ⑥ ACK return (Channel change completion notice)

◇ Control response (Source station output)

When the channels of the equipment in the system are changed, a control response is output as the change completion result.

- Source station control response output (changed to 14 channel)
*CH=0E CRLF

■ **4.4.5.3 '@DT05@CTxx/C' Issue target station test data**

Issues link test data from the specified target station for the time specified with the count value. The transmission data is the 'CrLF' sent repeatedly, and the receive response of the receiving station is '*DR=00'. If there is any input data during transmission, the data is transmitted. Note that once continuous data is issued from the target station, it can not be stopped by radio.

Format 1: '@' + 'DT05@CT' + '/C' + route information + 'CrLF'
 Format 2: '@' + 'DT05@CT' + '/C' + 'CrLF'

Details

Format 1: '@DT05@CT' xx '/C' rr,rr,...,rr 'CrLF'

Format 2: '@DT05@CT' xx '/C'CrLF'

xx: Count value: ASCII code that expresses 01h to FFh

The count value is 10 seconds per count. The maximum value is FFh, 2,550 seconds.

rr,rr,...,rr: Shows the route information in 2 hexadecimal digits and ASCII characters Value: 00h to FEh, number of relay stations maximum 10 units

The count value is 10 seconds per count. The maximum value is FFh, 2,550 seconds.

- With Format 1, the route information is entered directly in the command.
- With Format 2, transmission is based on route information set in the route register with the RT command or on the content of the Destination ID. When entering the route information, enter the Equipment ID of the target unit at the end. If no route information is set (NA set for the RT command), the equipment set as the Destination ID will be the target station.

Example: Issue a test signal for 60 seconds from the target station equipment number = 8F. The relay stations are 01 and 02.

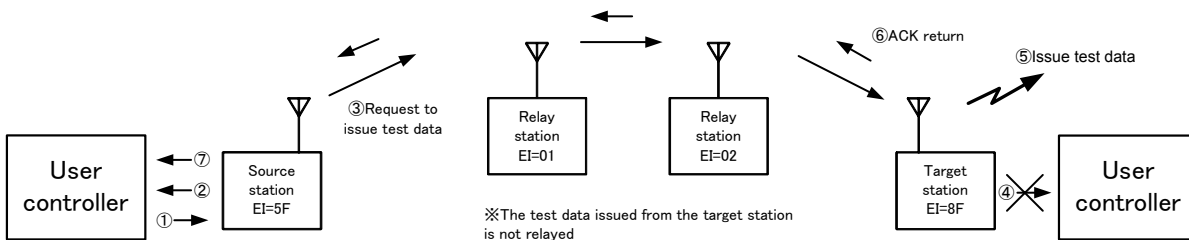

• Source station 5F status

- ① Issue the extended command
 Format 1: @DT 05 @CT 06 /C 01.02.8F CrLF
 Format 2: @DT 05 @CT 06 /C CrLF
- ② Extended response *DI=05 CrLF
- ③ Request to issue test data
- ⑦ ACK response (issued after the relay time has elapsed)
 *DR=05 @CT06 CrLF

• Target station 8F status

- ④ There is no data receive
- ⑤ Issue test data for 60 seconds
- ⑥ ACK return (Test data issue completion notice)

◇ **ACK response (Source station output)**

When test data is issued from the target station, the issue completion result is output as an ACK response.

- Source station ACK response output
 *DR=05 @CT06 CrLF

■ 4.4.6 Receive response

When issuing the monitor command and extended command, processing is performed at the target station and the result is returned to the source station. This processing result is output from the source station as a data receive. The content of the receive response depends on the command issued. For details, refer to the explanation of each command.

■ 4.4.7 ACK response

When issuing the extended command and so on, an 'ACK' is returned to show the target station receives the command. This 'ACK' is output from the source station as an ACK response. The content of the ACK response depends on the command issued. For details, refer to the explanation of each command.

■ 4.4.8 Error response

If there is an error in the format of the transmit command or control command issued, an error code of the type shown below is sent in response.

These error codes are required during product development, but you should ensure that errors do not occur with your product.

It is possible to change the display format by issuing the response display mode setting command '@RM=TX' or '@RM=CD'. In the default settings, only error codes are displayed.

Format : Prefix + response name + '=' + value + terminator

Prefix: '*' = 2Ah, a code that indicates the start of the response string.

Response name: The 2 ASCII characters 'ER'.

Value: Error code shown in the error code list.

Terminator: A code that indicates the end of the command 'C_RL_F' (0Dh, 0Ah).

Error response code

Response character string	Hexadecimal code actually returned from the MU-2-R
*ER= <u>ER</u> = <u>1D</u> C _R L _F	2A,45,52,3D,31,44,0D,0A

Example: Error response when the '@BR' command is issued

1. When the command '@RM=CD' is issued

*ER=0AC_RL_F

2. When the command '@RM=TX' is issued

*ER=0A: BR command format error C_RL_F

Error code list

Code	Description	Meaning
01	Issued command is not found	The issued command does not exist
02	Channel data error	The specified channel is outside the range
03	CH command error	Use a 2-digit Hex character for the 'CH' command
04	CH command format error	The 'CH' command format is wrong
05	DT command error	Use a 2-digit Hex character for the 'DT' command
06	DT command format error	The 'DT' command format is wrong. Check the data size.
07	-	
08	RA command format error	The 'RA' command format is wrong
09	RM command format error	The 'RM' command format is wrong
0A	BR command format error	The 'BR' command format is wrong
0B	-	
0C	MD command format error	The 'MD' command format is wrong
0D	DI command error	Use a 2-digit Hex character for the 'DI' command
0E	DI command format error	The 'DI' command format is wrong
0F	EI command error	Use a 2-digit Hex character for the 'EI' command
10	EI command format error	The 'EI' command format is wrong
11	TC command format error	The 'TC' command format is wrong
12	TB command format error	The 'TB' command format is wrong
13	Command input time exceeds limit	The time limit for inputting the command was exceeded
14	-	
15	CT command format error	The 'CT' command format is wrong
16	-	
17	UI command error	Use a 4-digit Hex character for the 'UI' command
18	UI command format error	The 'UI' command format is wrong
19	CS command format error	The 'CS' command format is wrong
1A	PB command format error	The 'PB' command format is wrong
1B	SB command format error	The 'SB' command format is wrong
1C	-	
1D	-	
1E	RT command format error	The 'RT' command format is wrong
1F	IZ command format error	The 'IZ' command format is wrong
20	SR command format error	The 'SR' command format is wrong
21	RI command format error	The 'RI' command format is wrong
22	SN command format error	The 'SN' command format is wrong
23	-	
24	SY command format error	The 'SY' command format is wrong
25	RC command format error	The 'RC' command format is wrong
26	SI command format error	The 'SI' command format is wrong
27	RR command format error	The 'RR' command format is wrong
28	RW command format error	The 'RW' command format is wrong
29	RA command format error	The 'RA' command format is wrong
2A	-	
2B	-	
2C	-	
2D	EC command format error	The 'EC' command format is wrong
2E	-	
2F	-	

Caution: The error codes for the CA, CP, and CR commands are the DT command errors 05 and 06.

Cautions

- As the radio module communicates using electronic radio waves, there may be cases where transmission is temporarily cut off due to the surrounding environment and method of usage. The manufacturer is exempt from all responsibility relating to resulting harm to personnel or equipment and other secondary damage.
- Do not use the equipment within the vicinity of devices that may malfunction as a result of electronic radio waves from the radio module.
- The manufacturer is exempt from all responsibility relating to secondary damage resulting from the operation, performance and reliability of equipment connected to the radio module.
- Communication performance will be affected by the surrounding environment, so communication tests should be carried out before actual use.
- Ensure that the power supply for the radio module is within the specified rating. Short circuits and reverse connections may result in overheating and damage and must be avoided at all costs.
- Ensure that the power supply has been switched off before attempting any wiring work.
- The case is connected to the GND terminal of the internal circuit, so do not make contact between the '+' side of the power supply terminal and the case.
- When batteries are used as the power source, avoid short circuits, recharging, dismantling, and pressure. Failure to observe this caution may result in the outbreak of fire, overheating and damage to the equipment. Remove the batteries when the equipment is not to be used for a long period of time. Failure to observe this caution may result in battery leaks and damage to the equipment.
- Do not use this equipment in vehicles with the windows closed, in locations where it is subject to direct sunlight, or in locations with extremely high humidity.
- The radio module is neither waterproof nor splash proof. ensure that it is not splashed with dirt or water. Do not use the equipment if water or other foreign matter has entered the case.
- Do not drop the radio module or otherwise subject it to strong shocks.
- Do not subject the equipment to condensation (including moving it from cold locations to locations with a significant increase in temperature.)
- Do not use the equipment in locations where it is likely to be affected by acid, alkalis, organic agents or corrosive gas.
- Do not bend or break the antenna. Metallic objects placed in the vicinity of the antenna will have a great effect on communication performance. As far as possible, ensure that the equipment is placed well away from metallic objects.
- The GND for the radio module will also affect communication performance. If possible, ensure that the case GND and the circuit GND are connected to a large GND pattern.

Warnings

- Do not take apart or modify the equipment.
- Do not remove the product label (the label attached to the upper surface of the module.) Using a module from which the label has been removed is prohibited.

Circuit Design, Inc. All rights reserved

No part of this document may be copied or distributed in part or in whole without the prior written consent of Circuit Design, Inc.

Customers are advised to consult with Circuit Design sales representatives before ordering.

Circuit Design, Inc. believes the information provided is accurate and reliable. However, Circuit Design, Inc. reserves the right to make changes to this product without notice.